

PART V

TOPICS IN COMPETITIVE ANALYSIS

CHAPTER 7

The Cournotian foundations
of Walrasian equilibrium theory:
an exposition of recent theory

Andreu Mas-Colell

1 Introduction

It is well known that the modern versions of Walrasian economics (Debreu (1959); Arrow and Hahn (1971)) leave unexplained a key ingredient of the theory, namely the hypothesis that prices are quoted and taken as given by economic agents. In this exposition we shall attempt, via the extensive analysis of two models, to give an account of the efforts of the last decade to develop the classical work of Cournot (1838) into a full-fledged general equilibrium theory that provides an endogenous explanation of price taking (we will say much less about price quoting). Specific references will be given as we go along. For a gathering of relevant articles see the issue of the *Journal of Economic Theory* (1980) on noncooperative approaches to the theory of perfect competition.

The starting point of the research is the (informal) hypothesis that economic agents interact noncooperatively through given institutions. Those being essential, it cannot be expected that the same level of institutional parsimoniousness as in Walrasian theory can be reached. Because, as a consequence, all-encompassing models are bound to be cumbersome, the research has proceeded by focusing on particular, pro-

This is an extended version of a lecture delivered at the Aix-en-Provence 4th World Congress of the Econometric Society in September 1980. I am indebted for support to National Science Foundation Grant SOC78-09934X and to the Instituto de Mathematica Pura e Aplicada at Rio de Janeiro.

totypical ones. This we shall do also. We will review two models. The first (Section 2), in the line initiated by Shubik (1973) and Shapley and Shubik (1977), is a model of exchange where all agents are treated symmetrically, that is, have, in principle, the same strategic position. The second (Section 3), in the line initiated by Gabszewicz and Vial (1972), Hart (1974a), and Novshek and Sonnenschein (1978), is a model of firms that face a sector of passively adjusting consumers but interact strategically among themselves.

Noncooperation means that agents take as given the strategies (in our case, in a strict Cournotian tradition, those are quantities) of the other agents. Obviously, this is a hypothesis that demands justification. We shall not, however, be concerned with it here on the grounds that it is plausible if individual agents are relatively small and the Cournotian explanation of price-taking equilibrium runs precisely in terms of the negligibility of single traders. There are noncooperative models where price taking holds at equilibrium irrespective of the number of agents (see, for example, Dubey (1981), Simon (1981), and, in a more normative spirit, Schmeidler (1980)). For these "Bertrandian" models the above specification of the noncooperation hypothesis can be questioned.

Before the development of the noncooperative approach, the body of economic theory was not at all empty of theoretical explanations for Walrasian equilibria. One had core theory and the core equivalence theorems (of Edgeworth, Debreu, Scarf, Aumann, Hildenbrand, and many others; see Hildenbrand (1974) for an almost definitive account), which were devised for precisely this purpose. We may be excused if we refer to Mas-Colell (1982) for a comparison of approaches and an argument that their differences are only a matter of degree and not of fundamental characteristics. Another, and more recent, important line of work, which we shall also not survey, is the theory of perfect competition put forward by Ostroy (1980) and Makowski (1980).

A serious limitation of our survey is that to keep things manageable we consider only the convex case. This means that in Section 3 we leave out some of the deepest research in the area, namely the work of Novshek and Sonnenschein (1978) on noncooperative Cournotian equilibrium with set-up costs for firms, by far the most relevant case. We may refer to Mas-Colell (1981) for an analysis of this case that ties in well with the results of Section 3. See also H. Sonnenschein, Chapter 8 in this book.

In tune with the work we review, we take the point of view that the appropriated solution concept for an economy \mathcal{E}_n with a finite number of agents (say n) is the Cournot noncooperative equilibrium. Then, if we look at an economy with a continuum of agents (see Aumann, 1964) as

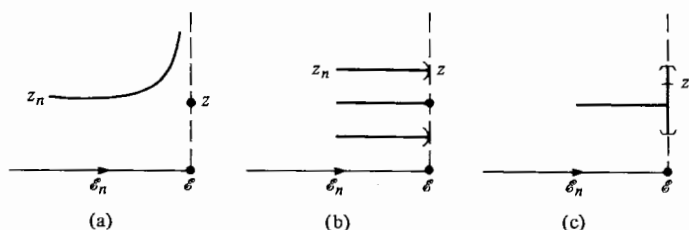

Figure 7.1

an idealization, that is, a model for an economy with many relatively small participants (i.e., large n), the central analytical question becomes to what extent the set of Walrasian equilibria of the continuum economy is also an “idealization” of the set of noncooperative equilibria of the large economies of which the continuum is a model. In other words, to what extent, if the finite economy \mathcal{E}_n is close to the continuum \mathcal{E} (in sequence terms, if $\mathcal{E}_n \rightarrow \mathcal{E}$), the set of Cournot equilibria of \mathcal{E}_n and the set of Walrasian equilibria of \mathcal{E} are similar.

A situation where it would be fully justified to call Walrasian theory the limit (as the economy grows large) of Cournotian theory would be one where for $\mathcal{E}_n \rightarrow \mathcal{E}$ the following three desiderata are satisfied (precise mathematical definitions will come in due course):

- (i) If z_n symbolizes a Cournot equilibrium for \mathcal{E}_n , then z_n should be bounded uniformly on n (in our models this is always equivalent to z_n having a convergent subsequence), that is, “escapes to infinity” do not arise.
- (ii) If $z_n \rightarrow z$ and z_n is a Cournot equilibrium for \mathcal{E}_n , then z is a Walrasian equilibrium of the continuum economy \mathcal{E} .
- (iii) If z is a Walrasian equilibrium of \mathcal{E} , then $z_n \rightarrow z$, for a sequence z_n of Cournot equilibria for \mathcal{E}_n .

Mathematically, (ii) is a closed graph property, (i) and (ii) yield upper hemicontinuity of the equilibrium correspondence, and (iii) gives lower hemicontinuity. Failures of (i), (ii), and (iii) are symbolically illustrated in Figures 7.1(a), (b), (c), respectively.

Roughly speaking, a failure of (i) or (ii) indicates that the Walrasian solutions (i.e., prices are quoted and taken as given) miss some possible noncooperative equilibria. Typically, those are not going to be satisfactory from the welfare theoretic point of view, and so one may be led astray by disregarding them. A failure of (iii) indicates that some Walrasian equilibria of the continuum model have no predictive value whatsoever or, as Novshek and Sonnenschein put it, that they are merely artifacts of the continuum specification.

We shall organize the presentation of Sections 2 and 3 around theorems giving sufficient conditions for (i), (ii), and (iii) to be satisfied. As it is usual in economic theory, a good deal of the interest of the results is the light thrown on new varieties of competitive failures. In this line, a tentative conclusion of our examination is that nonpathological failures of (ii) are quite possible. In contrast, the failures of (iii) tend to be more degenerate.

All the proofs are gathered in Section 4.

2 A symmetric model of competitive exchange

The model we shall discuss in this section belongs to the class introduced by Shubik (1973) and Shapley and Shubik (1977). It has been extensively developed by, among others, Dubey and Shubik (1977), Shapley (1976), Dubey and Shapley (1977), Pazner and Schmeidler (1976), Postlewaite and Schmeidler (1978), and Jaynes, Okuno, and Schmeidler (1978). A general axiomatic analysis was attempted in Dubey, Mas-Colell, and Shubik (1980). The particular variant we will analyze was briefly described as an example in the last reference. It differs from other variants in not striving for a strict game theoretic formulation. Thus, as an instance, the outcomes of our trade mechanism are ill defined outside of equilibrium. This could be repaired (in fact, our model is similar to the one of Jaynes, Okuno, and Schmeidler (1978) supplemented by an unlimited amount of credit), but from the standpoint of the objectives of this paper, nothing essential would be gained by doing so.

2.1 Description of an exchange economy

We begin by a brief description of the familiar concept of an exchange economy. To stick to the general equilibrium tradition (as exemplified in Debreu (1959) or Arrow and Hahn (1971)) we do not include the institutional arrangements for trade in the concept. Those will be introduced separately in the next subsection.

There are $l \geq 1$ commodities. The set of commodities will sometimes be denoted L . The characteristics of a *trader* are: (i) the *consumption set*, which for the sake of simplicity we take to be $R_+^l = \{v \in R^l : v \geq 0\}$; (ii) the *preference relation* \succeq on R_+^l which we take to be complete, transitive, continuous, strictly monotone (i.e., $v > v'$ implies $v > v'$) and convex (i.e., if $v \succeq v'$, then $\alpha v + (1 - \alpha)v' \succeq v'$ for all $0 \leq \alpha \leq 1$); (iii) the *endowments* ω , which for the sake of simplicity we take $\omega \gg 0$.

To save on notation and technicalities we shall restrict our attention

to a universe with a finite number of preference-endowment pairs $P = \{(\succeq_h, \omega_h)\}_{h=1}^m$.

Let I be a finite indexing set to be thought of as the set of trader's names. An *exchange economy* is then simply a map $\varepsilon: I \rightarrow P$. The characteristics of trader i are represented by $\varepsilon(i)$ and denoted (\succeq_i, ω_i) .

A net trader is a function $x: I \rightarrow R^l$ such that $\sum_{i \in I} x(i) \leq 0$. We also denote $x(i)$ by x_i . A net trader is (privately) *feasible* if $x_i + \omega_i \geq 0$ for all i . The interpretation is that x is an exchange among traders, trader i supplying $\max\{0, -x_i^j\}$ and getting $\max\{0, x_i^j\}$ of commodity j .

2.2 Trade and Cournot-Nash equilibria

Consider a fixed reference economy $\varepsilon: I \rightarrow P$.

Trade takes place in l trading posts or markets, one for each commodity. There is an extra commodity called numeraire and denoted m . It does not enter the utility functions, but it mediates trade, that is, in every market the exchange is of the good against the numeraire. The best interpretation of m is as a promise to pay note. Indeed, in principle, agents can pledge to trade any amount of numeraire they wish, but we impose as an equilibrium condition that no agent should be left with a net debit position.

The mechanics of trade are easily explained. Take agent i . For each market j , he must decide on a quantity of commodity j to offer $y_i^j \geq 0$, for short an *offer*, and a *bid* of numeraire $m_i^j \geq 0$. So, for each i we have a $2l$ vector of bids and offers $(m_i, y_i) \in R_+^{2l}$. Economywide, this yields two functions, $m: I \rightarrow R_+^l$, $y: I \rightarrow R_+^l$. The clearing rules in each market depend only on the bids and offers for that market. Specifically, given $m^j: I \rightarrow R_+$, $y^j: I \rightarrow R_+$, the aggregate bids and offers are $z^j = \sum_i m_i^j$, $z^{l+j} = \sum_i y_i^j$. Then, trader i gets a net amount $(z^{l+j}/z^j)m_i^j - y_i^j$ of the good j in exchange for a net amount $(z^j/z^{l+j})y_i^j - m_i^j$ of numeraire (by convention we put $0/0=0$ and $\infty \cdot 0=0$). The ratio z^j/z^{l+j} can be interpreted as a clearing price. Note the distinctly Cournotian quantity-setting flavor of this execution rule. We say that (m, y) is feasible for $i \in I$ if (i) the *budget constraint* is satisfied, that is to say, the total amount of numeraire bid by i in the different markets is not greater than the total amount of numeraire received in exchange for the offers, that is, $\sum_j m_i^j \leq \sum_j (z^j/z^{l+j})y_i^j$; and (ii) the offers are not greater than the initial endowments, that is, $y_i^j \leq \omega_i^j$ for all j . If (m, y) is feasible for i , we let $x_i[m, y]$ be the induced net trade of i . Note that

$$\sum_j (z^j/z^{l+j})x_i^j[m, y] \leq 0.$$

By (m, y) being *feasible*, we mean that it is feasible for each $i \in I$. The corresponding net trade function is $x[m, y] : I \rightarrow R^l$.

Observe that, in the spirit of an anonymity postulate for markets, nothing prevents agents from entering both sides of the same market, that is, from making both an offer and a bid. On the other hand, there is no possible gain in so doing. Indeed, let (m, y) be feasible and suppose that (m', y') differs from (m, y) only in that for some i and j , (m_i^j, y_i^j) has been replaced by $[m_i^j + \lambda, y_i^j + (z^{l+j}/z^j)\lambda]$ for some $\lambda \geq 0$, then we clearly have $x[m, y] = x[m', y']$. So, for each i and j the same net trade is obtained with a whole one-dimensional family of bids and offers pairs. Because, furthermore, which particular one is chosen does not affect the net trade of the other agents or of any other market, there is no conceptual loss if we always choose the representative (m_i^j, y_i^j) having $m_i^j y_i^j = 0$ (which obviously always exists). So, from now on, it is a maintained hypothesis that bids and offers $(m_i, y_i) \in R_+^{2l}$ satisfy the complementarity condition $m_i y_i = 0$. Note that even then net trades do not uniquely determine bids and offers. There is still one degree of freedom left. If (m, y) is feasible and $\lambda > 0$, then $x[m, y] = x[\lambda m, y]$.

Definition 1. A feasible $(m, y) : I \rightarrow R^{2l}$ is a *Cournot-Nash (CN) equilibrium* if for every $i \in I$, there is no (m', y') such that (m', y') is feasible for i , $x_i[m', y'] + \omega_i > x_i[m, y] + \omega_i$ and $m_{i'}' = m_{i'}$, $y_{i'}' = y_{i'}$ for all $i' \neq i$. We call $x[m, y]$ a Cournot-Nash net trade.

Given a feasible (m, y) it will be instructive to investigate the shape of the budget set $B_i(m, y) \subset R^l$ of agent i , that is, $B_i(m, y) = \{x_i : x_i[m', y'] : (m', y') \text{ is feasible for } i \text{ and } m_{i'}' = m_{i'}, y_{i'}' = y_{i'} \text{ for all } i' \neq i\}$. Put $\bar{m} = \sum_{i' \neq i} m_{i'}$, $\bar{y} = \sum_{i' \neq i} y_{i'}$ and assume that $\bar{m} \gg 0$ and $\bar{y} \gg 0$. Suppose that $x_i \in B_i(m, y)$. Then $-\omega_i \leq x_i \leq \bar{y}$. Further, if $x_i^j \leq 0$, the negative of the receipts from sales in market j is $[\bar{m}^j / (\bar{y}^j - x_i^j)] x_i^j$ and if $x_i^j > 0$, then denoting by v the numeraire outlays incurred we have $[(\bar{m}^j + v) / \bar{y}^j] x_i^j = v$, or $v = [\bar{m}^j / (\bar{y}^j - x_i^j)] x_i^j$. Therefore,

$$g(x_i) \equiv \sum_j \frac{\bar{m}^j}{\bar{y}^j - x_i^j} x_i^j \leq 0.$$

The converse clearly also holds, so $B_i(m, y) = \{x_i : -\omega_i \leq x_i \leq \bar{y}, g(x_i) \leq 0\}$. Because the function g is convex, the budget set is convex and closed. It is represented in Figure 7.2. If $\bar{m}^j = 0$ and $\bar{y}^j = 0$ for some j , then with the convention $0/0 = 0$, the above expression for $B_i(m, y)$ remains correct. The case where for some j , $\bar{m}^j > 0$, $\bar{y}^j = 0$ or $\bar{y}^j > 0$, $\bar{m}^j = 0$, we shall not need to worry about. It obviously cannot arise at equilibrium.

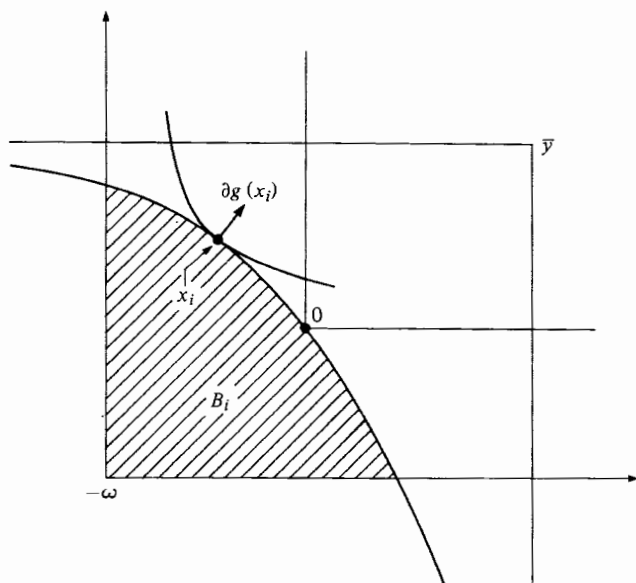

Figure 7.2

Because the budget sets are so well-behaved, it would not be surprising if an interesting existence theorem were available. We say interesting because the trivial null net trade (i.e., $m \equiv 0$, $y \equiv 0$) is always a CN equilibrium. On the other hand, if, for example, all agents are identical, then the sensible outcome is precisely no trade. What this means is that the search for interesting existence results must involve some minimal condition on the diversity of agents' characteristics. Such results are available for analogous models (Shapley and Shubik (1977), Dubey and Shubik (1977)), and without any doubt they can also be obtained for the present one. But the whole issue becomes delicate and is far from our main focus on limiting convergence properties. Thus, while we will have things to say about existence near the limit (Theorem 2), we shall not provide a general treatment.

For the asymptotic analysis, it is important to know that the equilibrium net trade of an agent cannot be arbitrarily large (so the situation depicted in Figure 7.1(a) can be ruled out).

Proposition 1. There is a $k > 0$ (depending only on P) such that if (m, y) is a CN equilibrium for an economy $\mathcal{E} : I \rightarrow P$, then $|x_i^j[m, y]| \leq k$ for all i and j .

Let (m, y) be a CN equilibrium for $\varepsilon: I \rightarrow P$. Because of the strict monotonicity of preferences, the situation where for some j , $\sum_j m_i^j = 0$ and $\sum_i y_i^j > 0$ or $\sum_i m_i^j > 0$ and $\sum_i y_i^j = 0$ cannot arise. On the other hand, $\sum_i m_i^j = 0$ and $\sum_i y_i^j = 0$ is entirely possible. In this case, we say that the market j is *inactive*. In fact, in this trading model the inactivity of any set of markets at equilibrium can be prescribed a priori. To see this, take an arbitrary set of markets and close them (i.e., eliminate them from the model). Find an equilibrium for the set of remaining markets. Then the equilibrium net trade will still be an equilibrium if the markets of the first set are reopened. Although trade is now possible in principle, no single agent has any incentive to make any bids or offers in those markets and therefore they remain inactive.

2.3 Limit economies: Cournot-Nash and Walrasian equilibria

An economy with a *continuum of agents* can be modeled as in Section 2.1. We only need to interpret I as the interval $[0, 1]$ and systematically replace Σ by \int . Of course, familiar technical measurability requirements must also be imposed. We should also, where appropriate, read “almost all” for “all.”

Similarly, the notion of a Cournot-Nash equilibrium pair of (measurable) bids and offers functions $(m, y): I \rightarrow R_+^L$ and of a corresponding Cournot-Nash net trade $x[m, y]: I \rightarrow R^L$ still makes sense. What is the shape of a typical budget set $B_i(m, y)$, $i \in I$? For a CN equilibrium (m, y) , let $A \subset L$ be the set of active markets, that is, $j \in A$ if and only if $z^j = \int m^j > 0$ and $z^{l+j} = \int y^j > 0$ (equivalently, $j \in A$ if and only if $\int |x^j[m, y]| > 0$). Then,

$$B_i(m, y) = \{x_i \in R^L: -\omega_i \leq x_i, \sum_{j \in A} \frac{z^j}{z^{l+j}} x_i^j \leq 0$$

$$\text{and } x_i^j = 0 \text{ for } j \notin A\}.$$

Remember that now z^j and z^{l+j} have the interpretations of averages. Since the value of an integral does not depend on the value of the integrand on a set of measure zero, z^j and z^{l+j} do not depend on the bids and offers of a particular agent. Therefore, what the expression for $B_i(m, y)$ tells us is that at a CN equilibrium every agent faces the same market constraints: trade is not possible in inactive markets, while in active markets trade is possible (in an amount limited only by the availability of commodities to supply) at the fixed trade ratio z^j/z^{l+j} .

If at a CN equilibrium (m, y) every market is active, then $B_i(m, y)$ is a familiar Walrasian budget set and the CN net trade is a Walrasian net trade. If the set of active markets A is smaller than L , then we can still

say that the CN net trade is Walrasian with respect to A if by this we mean that in the definition of Walrasian equilibrium we take the markets in $L \setminus A$ to be closed.

Definition 2: Given the economy $\mathcal{E}: [0, 1] \rightarrow P$, a feasible net trade function $x: [0, 1] \rightarrow R^l$ is Walrasian with respect to $A \subset L$ if $x_i^j = 0$ for $j \notin A$ and all $i \in [0, 1]$, and if for each $j \in A$ there is $p^j \geq 0$ such that, for all $i \in [0, 1]$, $x_i + \omega_i$ is \succeq_i maximal on $\{v + \omega_i: \sum_{j \in A} p^j v^j \leq 0, v^j = 0 \text{ for } j \in A\}$.

Then every CN equilibrium net trade is Walrasian with respect to its set of active markets. Conversely, it is trivially verified that a net trade that is Walrasian with respect to some $A \subset L$ can be sustained as a CN net trade. Observe that at a Walrasian equilibrium it is entirely possible for a market to be open but not active. But at an open market there must be a price quoted. If the market is active, we can identify the price with a certain ratio of supply and demand. If the market is not active, this is not so and we must be implicitly resorting to some institutional device for price quoting.

If all markets are open, then we have the usual notion of Walrasian equilibrium to which the familiar Pareto optimality properties apply.

2.4 Large finite economies; sequences and convergence

We have seen in the previous section that in a limit economy the CN net trades are precisely the same as the net trades that are Walrasian in a generalized sense which allows for closed markets. We are, however, interested in the continuum set-up and corresponding results only to the extent that they are a model for large finite economies. What we want is that if a finite economy is near the limit, its equilibrium set be similar to the equilibrium set of the limit. To formulate this property requires a notion of "nearness" for economies and net trade functions, or, more directly, a notion of convergence of finite economies and their net trades to limit economies and net trades. This we proceed to provide in this section.

Consider a sequence of finite economies $\mathcal{E}_n: I_n \rightarrow P$ with $\#(I_n) = n$ and a continuum economy $\mathcal{E}: I \rightarrow P$, $I = [0, 1]$. Dealing as we are with a finite number of types, the meaning of $\mathcal{E}_n \rightarrow \mathcal{E}$ is straightforward. We say that $\mathcal{E}_n \rightarrow \mathcal{E}$ if for each type h the fraction of agents of type h in economy \mathcal{E}_n converges to the corresponding fraction in \mathcal{E} , or

$$(1/n)\#\{i: \mathcal{E}_n(i) = (\succeq_h, \omega_h)\} \rightarrow \lambda(\mathcal{E}^{-1}(\succeq_h, \omega_h)),$$

where λ denotes Lebesgue measure.

Now let $x_n: I_n \rightarrow R^l$, $x: I \rightarrow R^l$ be net trades for \mathcal{E}_n , \mathcal{E} , respectively. In the sequel we will need only to consider CN equilibrium net trades. To attach a meaning to $x_n \rightarrow x$ take first the simplest case where x_n , x are symmetric, that is, net trades are the same for agents of the same type. Then we require that for every h , $x_{nh} \rightarrow x_h$ where x_{nh} , x_h denote the net trade of agents of type h in the economies \mathcal{E}_n , \mathcal{E} . If x_n , x are not symmetric, matters become slightly more delicate, but they can be handled by standard techniques. What one does is take measures μ_{nh} , μ_h , on R^l , which (up to a multiple) stand for the distribution over net trades of the traders of type h in the economies \mathcal{E}_n , \mathcal{E} , and require that, for all h , $\mu_{nh} \rightarrow \mu_h$ in the sense of the weak convergence for measures. More precisely, μ_{nh} is defined by letting, for any $B \subset R^l$,

$$\mu_{nh}(B) = (1/n) \# \{i \in I_{nh} : x_n(i) \in B\},$$

where $I_{nh} \subset I_n$ are the agents of type h . The measure μ_h is defined similarly. For " $\mu_n \rightarrow \mu$ weakly," it is meant that for every continuous bounded function $f: R^l \rightarrow R$ we have $\int f d\mu_n \rightarrow \int f d\mu$. See Hildenbrand (1974) for this.

2.5 The limit of a sequence of CN equilibria

Let $\mathcal{E}_n: I_n \rightarrow P$, $\#I_n = n$, be a sequence of finite economies converging, in the sense of the previous section, to a limit \mathcal{E} . Suppose that $x_n: I_n \rightarrow P$ are CN net trades for \mathcal{E}_n . By Proposition 1 we know that for all n and $i \in I_n$, $x_n(i) \in K = \{v \in R^l : \|v\| \leq k\}$, that is, independently of n and i net trades belong to a fixed bounded subset of R^l . The "escape to infinity" situation of Figure 7.1(a) cannot arise. This has an economic interpretation. It says that in this model it is guaranteed that if traders become relatively small in terms of initial endowments and if there is no singularity in their preferences (i.e., there are many traders of each possible characteristic), then the potential gains from trade of individual agents are limited. We cannot have the paradox where by treating similar agents dissimilarly some individual agents turn out at equilibrium to be relatively large in terms of their net trades.

So, let's assume that $x_n \rightarrow x$ where $x: I \rightarrow K$. What are the properties of x ? Since at the limit every CN net trade is Walrasian with respect to some ACL , it is natural to expect that this will also be the case for x . The next theorem establishes this. Analogous results have been proved in the references at the beginning of Section 2.

Theorem 1. Let $\mathcal{E}_n \rightarrow \mathcal{E}$ and $x_n: I_n \rightarrow R^l$ be a sequence of CN equilibrium for \mathcal{E}_n . Then:

- (i) x_n has a subsequence converging to some $x: I \rightarrow K$;
 (ii) If $x_n \rightarrow x$, then x is Walrasian with respect to $A = \{j \in L : |x^j| > 0\}$.

Theorem 1 provides a (limited) justification for a "Cournot conjecture" on the Pareto optimality of noncooperative equilibria of economies with relatively small individual agents. If at the limit x all markets are active, then we indeed have a Walrasian fully (Pareto) optimal equilibrium, but, in general, we are only permitted to claim optimality with respect to reallocations of commodities with active markets. As has been pointed out in Sections 2.3 and 2.4, there is nothing pathological about this. Failures such as the ones illustrated in Figure 7.1(b), where the limit of a sequence of CN equilibria is not fully Walrasian, or even Pareto optimal, are entirely possible. Within the present model competitive forces are too weak to activate markets that should be active for optimality (in fact, to activate markets at all). The reason is that to start trading in an inactive market a minimum of cooperation among at least two agents (a buyer and a seller) is necessary, but the Cournot-Nash concept does not capture, in this model, such cooperation.

The proof of Theorem 1 does not depend in any essential way on the finiteness of P . A "compactness" property would do. As previously asserted, part (i) follows from Proposition 1 (the proof of which is somewhat technical). Part (ii) is intuitive and the proof is straightforward.

2.6 *Approximating Walrasian by Cournot-Nash equilibria*

We now investigate our problem in the other direction: Given a fully (i.e., all markets are open) Walrasian net trade $x: I \rightarrow R^l$ for a continuum economy \mathcal{E} and given a sequence of approximating finite economies $\mathcal{E}_n \rightarrow \mathcal{E}$, can we find a sequence $x_n \rightarrow x$ such that (except perhaps for at most a finite number of terms of the sequence) x_n is a CN net trade for \mathcal{E}_n ? With this generality a positive answer cannot be expected. If, to begin with, x is a Walrasian equilibrium only by coincidence and a small perturbation of the data of the economy makes it disappear, then there is no reason why it should be preserved as a CN equilibrium when the economy is perturbed from the continuum to a finite but large approximation. In addition, the nonrobustness of a coincidental Walrasian equilibrium makes it a doubtful theoretical solution concept for what are, inherently, imprecise models of the economy.

This suggests that the whole question should be placed in, or restricted to, a framework of regular economies, that is, of economies \mathcal{E} having a set of (Walrasian) equilibria persistent under perturbations. The theory of regular economies, initiated by Debreu (1970), has since been extensively developed. See Dierker (1977) for a survey.

It will be convenient (but, we wish to emphasize, far from necessary) to impose smoothness conditions on preferences. Specifically, we will, for the rest of this section, assume that for every type h , \succeq_h is representable by a C^2 utility function $u_h: R_+^l \rightarrow R$ with no critical point. Also, the indifference surfaces of \succeq_h have everywhere nonzero curvature. Given our convexity hypothesis on \succeq_h , this is a kind of differentiable strict convexity, and it is equivalent (see Debreu (1972)) to the condition that for all $x \in R_+^l$

$$\begin{vmatrix} \partial^2 u(x) & \partial u(x) \\ (\partial u(x))^T & 0 \end{vmatrix} \neq 0$$

Let $p \in R_{++}^{l-1}$. We interpret p as prices for the first $l-1$ commodities relative to the l th. That is to say, we normalize the price of the l th commodity to be 1. Then, for each type h , an *excess demand function* $\hat{f}_h: R_{++}^l \rightarrow R^l$ is defined by letting $\hat{f}_h(p) + \omega_h$ maximize \succeq_h on

$$\left\{ v \in R_+^l : \sum_{j=1}^{l-1} p^j (x^j - \omega_h^j) + (v^l - \omega_h^l) \leq 0 \right\}.$$

It is, of course, well known that \hat{f}_h is C^2 whenever $\hat{f}_h(p) + \omega_h \gg 0$ (see Debreu (1972)). Define $d_h(p)$ (resp. $s_h(p)$), by $d_h^j(p) = \max\{0, \hat{f}_h^j(p)\}$ (resp. $s_h^j(p) = -\min\{0, \hat{f}_h^j(p)\}$). Of course, $\hat{f}_h(p) = d_h(p) - s_h(p)$. The symbols d and s stand for demand and supply.

In the economy \mathcal{E} we have the corresponding aggregate functions \hat{f} , d , and s , that is, if we let θ^h be the fraction of agents of type h , then $\hat{f} = \sum_h \theta^h \hat{f}_h$ and similarly for d and s . We let $f: R_{++}^{l-1} \rightarrow R^{l-1}$ be defined by deleting the last coordinate from \hat{f} . Note that $\hat{f}^l(p) = -p \cdot f(p)$.

Let x be a fully Walrasian equilibrium net trade for \mathcal{E} . Then, by definition, there is p such that for any i if h is the type of i , then $x_i = \hat{f}_h(p)$. So, x is symmetric and there is a one-to-one correspondence between equilibrium net trades and equilibrium prices, that is, vectors p such that $\hat{f}(p) = 0$. By the strict monotonicity hypothesis on preferences $p \gg 0$ is guaranteed.

It will be convenient that at the equilibrium p under consideration the three functions \hat{f}_h , d_h , s_h be C^1 . This will be so if the following condition is satisfied, (H) for all h and j , $0 \neq \hat{f}_h^j(p) > -\omega_h^j$.

Definition 3. A Walrasian net trade $x: I \rightarrow R^l$ for \mathcal{E} with corresponding $p \in R_{++}^{l-1}$ is *regular* if:

- (i) condition (H) holds; and
- (ii) $\text{rank } Df(p) = l-1$.

Condition (ii) is the standard regularity assumption for exchange

economies (see Dierker (1977) survey). Condition (i) is specific to our problem and it is imposed merely for convenience of the proof technique; it is not essential. Regularity of the equilibria is not a restrictive hypothesis. Typically, it will be satisfied, in the sense that except for a "negligible" set of economies every Walrasian equilibrium of an economy will be regular (see Debreu (1970) and Dierker (1977)).

Theorem 2. Let $\mathcal{E}: [0, 1] \rightarrow P$ be a continuum economy and $x: [0, 1] \rightarrow R^l$ a regular (fully) Walrasian equilibrium. Suppose that $\mathcal{E}_n \rightarrow \mathcal{E}$. Then there is N and a sequence $x_n: I_n \rightarrow R^l$, $n > N$, of CN net trade equilibria for \mathcal{E}_n such that $x_n \rightarrow x$. Further, every x_n is symmetric and, up to differences in a finite number of entries, the sequence is unique.

Theorem 2 is quite satisfactory. Note that, in particular, if we admit the existence of Walrasian equilibrium at the limit, it yields an existence result of CN equilibria for large, but finite, economies. The interpretation of the theorem is clear. In the trade model under consideration, failures of the type illustrated in Figure 7.1(c) can arise only in degenerate (nonregular) cases. Thus, typically, every Walrasian equilibrium represents a noncooperative Cournot-Nash equilibrium of the finite but large economy of which the continuum is a model.

Theorem 2 has been stated for Walrasian equilibria with a full set of open markets, but it is obvious that mutatis mutandis it applies to any Walrasian equilibria. In addition, condition (H) implies that at the considered equilibrium every open market is active. This is a side effect of the convenience hypothesis (H) and it is not an essential part of the definition of regularity. As a final observation we note that the proof of Theorem 2 we shall give does not depend in any essential way on the finiteness of P . The theorem remains true for "compact" P .

3 A model of competition among firms

In this section we present and analyze a model that is much closer to the original partial equilibrium example of Cournot than the one in Section 2. Here we will have firms and consumers. The first are strategically active via quantity competition, while the second adapt passively along a kind of general equilibrium demand curve. The model originates in Gabszewicz and Vial (1972), Hart (1979), Roberts and Sonnenschein (1977), and Novshek and Sonnenschein (1978). For simplicity, we consider only the convex production case. Our treatment of it owes much to a paper by Roberts (1980). For an analysis of the nonconvex case see Novshek and Sonnenschein (1978) and Mas-Colell (1981).

3.1 Description of the economy

There are l commodities. An economy is composed of a consumption and a production sector. The strategically active agents are the producing firms (finite in number). The consumption sector is to be thought as a continuum of consumers that adapt passively to the production decisions of the firms. We will describe it first.

Formally, the consumption sector is defined by a *consumption-feasible set of aggregate productions* $J \subset R^l$ and a set-valued mapping $P: J \rightarrow R^l$ which to each $z \in J$ assigns a nonempty set of possible equilibrium prices $P(z)$. The correspondence P is to be interpreted as a general equilibrium analogue of the familiar partial equilibrium inverse demand function (an early precedent is the concept of "total demand curve" of I. Pierce (1952-53)). More specifically, let there be a population of consumers characterized by preferences, endowments, and shareholdings (as in Debreu (1959) or Arrow and Hahn (1971)). Suppose that every consumer has a uniform-across-firms share of profits. Then the profit income of every consumer depends only on the aggregate net production z and on the prevalent price vector p . So, given z we have a well-defined Walrasian general equilibrium system for which the set of equilibrium prices is $P(z)$. Of course, $P(z) = \emptyset$ is possible. The region J is precisely the set of those z for which $P(z) \neq \emptyset$. The hypothesis of uniformity over firms of profit shares of each consumer is implicit in our analysis because we take equilibrium prices to depend on aggregate production. The more general case would require a more disaggregated domain for P . There is no essential difficulty involved in allowing for it, but in this exposition we wish to keep things as simple as possible. For illustrative purposes we will next give two examples of consumption sectors.

Example 1. There are two commodities. If we assume that all consumers are identical, share equally in profits (or losses), have initial endowments $(2, 2)$, and convex, monotone preferences \succeq on R_+^2 , then

$$J = R_+^2 - \{(2, 2)\} \quad \text{and} \quad P(z) = \{p \in R_+^2 : pz' \succeq pz \text{ for all } z' \succeq z\}.$$

Example 2. There are two commodities and two classes of consumers (of equal weight), owners and nonowners. Owners have initial endowments $(0, a)$, consumption set R_+^2 , share in profits (or losses) equally, and care only about commodity 2 which we shall choose as numeraire with price fixed at 1. Nonowners do not receive profits. For the purposes at hand it suffices to describe them by their aggregate continuous excess demand function $\varphi: R_{++}^2 \rightarrow R^2$. We do not require that nonowners be identical. Therefore, by the known characterization results for excess demand

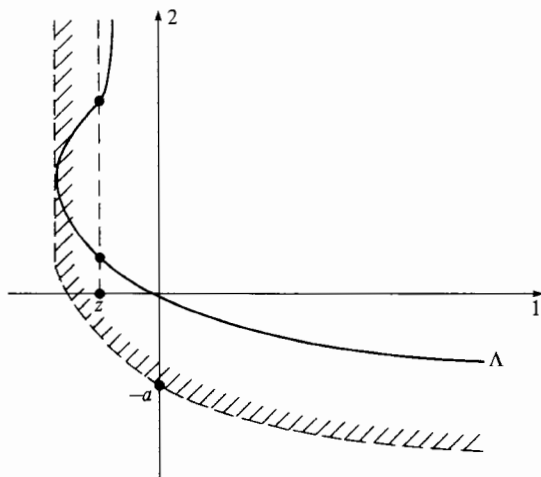

Figure 7.3

functions (see Shafer and Sonnenschein (1982)), φ is essentially unrestricted. See Figure 7.3, in which we represent the offer curve $\Lambda = \varphi(R_{++}^2)$. For this consumption sector we have

$$J = \varphi(R_{++}^2) + (\{0\} \times [-a, \infty))$$

and $P(z) = \{(q, 1) : z - \varphi(q, 1) = (0, \lambda)\}$, $z \in J$. It is worth noting that in contrast to Example 1, the region J and the correspondence P are not specially well behaved. Thus, for example, in Figure 7.1 to the production z there correspond two price equilibria. Observe also that $P(z)$ does not depend on z^2 , the amount of the numeraire commodity.

As for the *production sector* we assume that there is a finite number of types of production sets $Y_1, \dots, Y_m \subset R^l$. Each Y_h is closed, convex, bounded above, and satisfies $Y_h \cap R_+^l = \{0\}$. We let $\mathbf{Y} = \{Y_1, \dots, Y_m\}$ and $\hat{Y} = \text{convex hull } \bigcup_h Y_h$. A production sector is then a map $Y: I \rightarrow \mathbf{Y}$ where I is a finite indexing set. A *production* is a function $y: I \rightarrow R^l$. A production is *feasible* if $y(i) \in Y(i)$ for all $i \in I$. We let $\bar{Y} = [1/\#(I)] \sum_{i \in I} Y(i)$ and $\bar{y} = [1/\#(I)] \sum_{i \in I} y(i)$. Note that $\bar{Y} \subset \hat{Y}$. As in Section 2, little in our analysis depends on the finiteness (rather than "compactness") of \mathbf{Y} .

An economy \mathcal{E} is then defined to be the pair $P: J \rightarrow R^l$, $Y: I \rightarrow \mathbf{Y}$. A production $y: I \rightarrow R^l$ is *attainable* if it is feasible and, also, consumption feasible, that is, $\bar{y} \in J$. An *attainable state* of the economy is a pair (y, p) where y is an attainable production and $p \in P(\bar{y})$. Note that we are measuring magnitudes in per-firm terms.

3.2 Cournot-Nash equilibrium

To develop a notion of noncooperative equilibrium for the economies under consideration we will now have to take a major leap and postulate that the behavior of the strategic players, that is, the firms, is directed by the profit maximization motive. There are at least two serious conceptual problems associated with this. The first is the justification of the profit objective itself (why not utility or surplus or sales maximization?). The second is how to evaluate profits. Even if a numeraire has been chosen, the price equilibrium correspondence may be multivalued for some \bar{y} and so, profits not unambiguously determined. We comment on these two difficulties in turn.

In the case of large economies (i.e., for economies near the continuum of firms limit), the profit maximization objective has been investigated and justified as being susceptible of conveying the exact or approximate unanimous approval of owners. See Hart (1979b), Novshek and Sonnenschein (1978), and also, Makowski (1980b). To the extent that we concern ourselves only with limiting properties, those are comforting results. It is somewhat surprising, however, that no careful investigation of this basic aspect of a theory of monopolistic competition seems to be available for the general case. We may mention here that the justification of the profit motive is intimately related to guaranteeing the invariance of results with respect to the choice of numeraire, a property that any minimally satisfactory theory should possess.

We feel that the problem is important enough for us to wish to make sure that at the very least there is a consistent scenario in which profit maximization is fully justified. The following will do: One commodity is the numeraire with price fixed at 1. Think of it as a Hicksian composite commodity available in an extensive "outside world." Agents have preferences, endowments, and shareholdings. However, we impose the restriction that agents with positive share ownership in firms care only about the numeraire commodity (which is therefore endogenously determined). Perhaps they live in the outside world. Then, of course, utility maximization on the part of owners resolves in profit maximization on the part of firms. Observe that this interpretation moves the model in the direction of partial equilibrium, but not so much as to lose any of the essential general equilibrium complexities. In particular, income effects are present and J and P can still be quite complicated. In fact, Example 2 (and every example from now on) belongs to the variety discussed in this paragraph.

There remains the second problem. Even if a natural numeraire exists and prices are normalized with respect to it, the set $P(z)$ may not be a

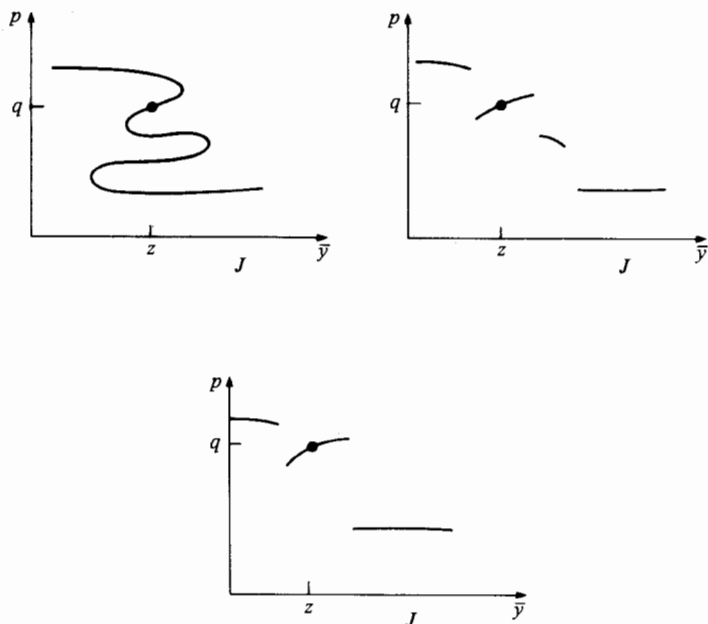

Figure 7.4

singleton (see Figures 7.4 and 7.9). To have a prevailing (i.e., “historically given”) z and $q \in P(z)$ will not help because profit maximization will involve the consideration of hypothetical z' . However, for z' near z , it is natural to require that the price prediction be determined, if at all possible, by continuity from q (see Figure 7.4). As it turns out, this is all that will be needed for our (large economies) results. Therefore, even if this is a serious conceptual problem, it has no drastic consequences for our analysis and we will formally proceed along the standard lines by assuming that there is an a priori given selection $p : J \rightarrow R^l$ from P , that is, $p(z) \in P(z)$, which associates to every consumption feasible production z a predicted price vector. The selection p substitutes for the incompleteness (in the sense of being unable to always provide a concrete prediction in the form, perhaps, of a random variable) of the theory, in this case, Walrasian exchange, underlying the generation of P . In Figures 7.4(b) and (c) we have two different selections from the P of Figure 7.4(a). Note that both of them are maximally continuous through the point (z, q) .

The definition of a Cournot–Nash production should now be self-explanatory.

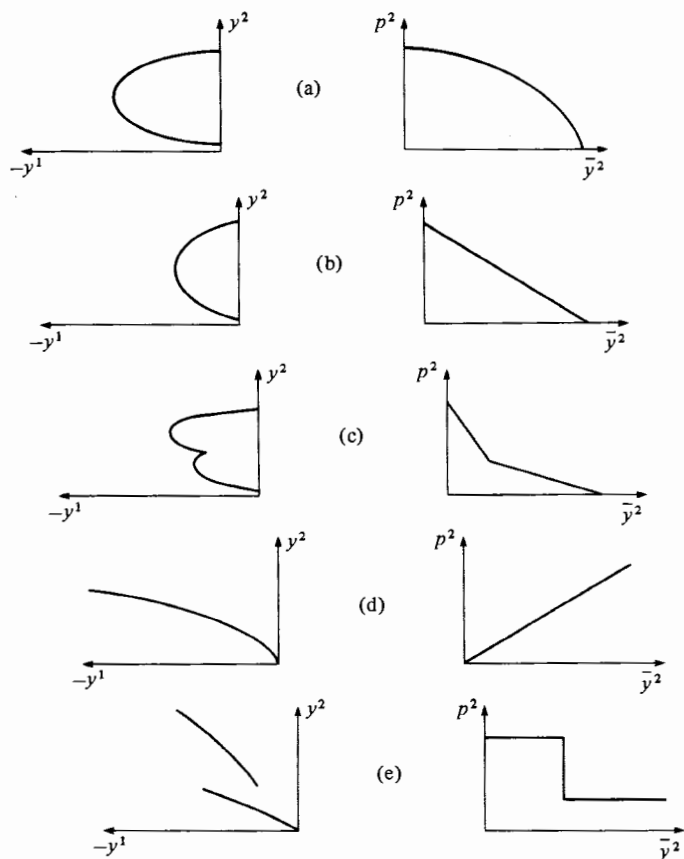

Figure 7.5

Definition 4. Given the production sector $Y: I \rightarrow \mathbf{Y}$, the attainable production $y: I \rightarrow R^I$ is a Cournot-Nash (CN) equilibrium with respect to the selection $p: J \rightarrow R^I$ if for all $i \in I$ we have $p(\bar{y})y_i \geq p(\bar{y}')y'_i$ for all attainable $y': I \rightarrow R^I$ such that $y'_i = y_i$ for $i' \neq i$.

In other words, each firm maximizes profits given the production of the remaining firms. Observe that the isoprofit surfaces of a firm i can be determined from the aggregate production of the remaining firms. Figure 7.5 illustrates several possibilities for the zero isoprofit line of a firm. (The remaining are obtained by horizontal displacement. We implicitly take $p^1 = 1$ and assume that p^2 depends only on \bar{y}^2 ; because the production of the other firms is fixed, we may as well suppose that there is no other firm.)

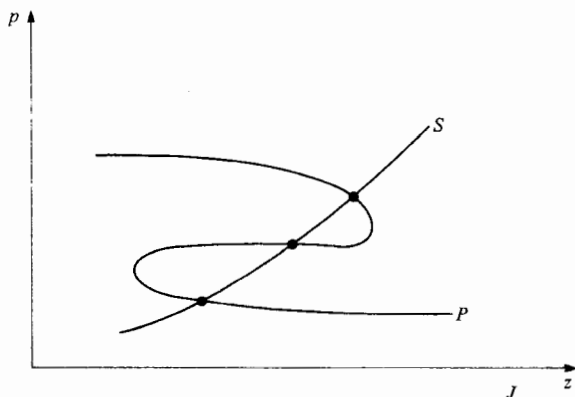

Figure 7.6

3.3 Continuum economies and Walrasian equilibrium

An economy with a continuum of firms is defined exactly as in Section 3.1 except that we interpret I as $[0, 1]$ (and “all” as “almost all”), replace the sums by integrals, and require all functions to be measurable.

An attainable state (y, p) will be called Walrasian if all firms maximize profits taking q as given, that is, $y(i)$ solves the problem “Max qz subject to $z \in Y(i)$.” For reasons of symmetry we give a formal definition in terms of demand and supply. For each type of production set Y_h let θ^h be the fraction of firms having this production set. For each $q \in R^l_+$ let $S_h(q)$ be the set of maximizers of qz on Y_h ; $S_h(q)$ is convex (possibly empty). Let $S(q) = \sum_h \theta^h S_h(q)$. Then, $S(q)$ is the aggregate Walrasian supply set corresponding to q . If $z \in S(q)$ we can find $y: I \rightarrow R^l$ such that $\bar{y} = z$ and $y(i)$ is profit maximizing for each $i \in I$. Therefore, the following definition makes sense.

Definition 5. The $(z, p) \in J \times R^l$ is a Walrasian equilibrium of the economy specified by $P: J \rightarrow R^l$ and $Y: [0, 1] \rightarrow \mathbf{Y}$ if:

- (i) $p \in P(z)$, and (ii) $z \in S(p)$.

In other words, (z, p) is a common point of the graph of the supply and demand correspondences. See Figure 7.6 where there are three Walrasian equilibria.

3.4 Large finite economies; sequences and convergences

Given a continuum economy \mathcal{E} , we wish to attach a meaning to $\mathcal{E}_n \rightarrow \mathcal{E}$ where \mathcal{E}_n are economies with a finite number of firms. For the sake of

expositional simplicity we limit ourselves drastically and take the consumption sector to be the same (in per-firm terms) for all $\mathcal{E}_n, \mathcal{E}$. Then, given the corresponding production sectors $Y_n: I_n \rightarrow Y$, we say that $Y_n \rightarrow Y$ if, for every h , $\theta_n^h \rightarrow \theta^h$ where $\theta_n^h = [1/\#(I_n)] \#\{i: Y(i) = Y_h\}$ and analogously for θ^h . Similarly to Section 2, if $y_n: I_n \rightarrow R^l$, $y: [0, 1] \rightarrow R^l$ are productions, we say that $y_n \rightarrow y$ if for each h we have $\mu_{nh} \rightarrow \mu_h$ weakly, where μ_{nh} is the measure in R^l defined by

$$\mu_{nh}(B) = \frac{1}{\#(I_n)} \#\{i \in I_n: Y(i) = Y_h \text{ and } y_n(i) \in B\}.$$

A word on relative sizes as $n \rightarrow \infty$ may be useful. Implicitly, we always take single consumers to be of negligible size relative to the dimension of a single firm (measured somewhat coarsely by, say, the capacity production). This remains unaltered for all \mathcal{E}_n (and also for \mathcal{E}), and it is the justification for the passive reactive behavior of consumers. What becomes smaller as $n \rightarrow \infty$ is the size of a single firm relative to the size of the entire economy. For example, if to begin with we have a set of firms and a continuum of consumers, we can obtain a sequence of economies converging to a limit with a continuum of firms in the sense of this section if we replicate *pari passu* both the set of firms and of consumers.

3.5 The limit of a sequence of CN equilibria

Let $\mathcal{E}_n \rightarrow \mathcal{E}$ and $y_n: I_n \rightarrow R^l$ be a sequence of CN productions for \mathcal{E}_n . Example 3 shows that even if J is bounded below (as it should be), y_n may not be bounded above.

Example 3. There are two commodities and only one firm type with a production set as in Figure 7.7. Note that although total output is bounded, input productivity is always positive. The set J is $R_+^2 - (1, 0)$ and $P(z) = (0, 1)$ for $z^2 \leq 1 + z^1$ or $z^1 \geq 0$, and

$$P(z) = \{(0, 1), (-(1 + z^1)/z^1, 1)\}$$

otherwise. Thus, P is compatible with the following specification of the consumption sector. There are owners and nonowners. Owners share equally in profits, have no endowments, and only care about commodity 2. Nonowners are endowed (in mean) with one unit of commodity 1 and have L -shaped indifference curves.

The economies \mathcal{E}_n differ only in the number of firms, which is n in economy \mathcal{E}_n . We claim that a CN equilibrium $y_n: I_n \rightarrow R^l$ is given by letting $y_n(i) = 0$ for $i \neq 1$ and $y_n(1) = (-n, a_n)$ where a_n is the maximal

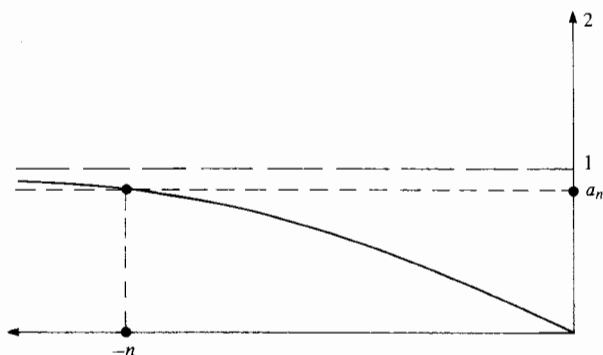

Figure 7.7

feasible production with input requirement n . Of course, y_n is not bounded. It is trivial to verify that it is an equilibrium. The key observation is that \bar{y}_n is at the boundary of J .

There are two avenues to correct the situation of Example 3. One would be to investigate and impose appropriate boundary conditions on P . This would take us too far afield, and, besides, it is not clear what they would be (the boundedness of prices away from zero and infinity would do for this example but not for Example 4). The second one that, out of expediency, we shall follow is to require $\hat{Y} \subset J$. Because $\bar{Y}_n \subset \hat{Y}$, this implies that any feasible production is attainable. In other words, the consumption sector is very extensive relative to the production sector. Of course, if J is bounded below, then $\hat{Y} \subset J$ implies that each Y_h is bounded above and below. Therefore, if y_n is a sequence of CN equilibria, it is necessarily bounded and has a convergent subsequence (see proof of Theorem 1).

Theorem 3, which is easy, gives sufficient conditions for the limit of a sequence of CN equilibria to be Walrasian and therefore Pareto optimal.

Theorem 3. Suppose that $\hat{Y} \subset J$ and $P: J \rightarrow R^l$ is a continuous function. If $\varepsilon_n \rightarrow \varepsilon$, y_n is a CN production for ε_n and $y_n \rightarrow y$, then y is a Walrasian production for ε .

Results along the lines of Theorem 3 have been provided by Gabszewicz and Vial (1972), Novshek and Sonnenschein (1978), Hart (1979), and Roberts (1980). Example 4 shows that the condition $\hat{Y} \subset J$ cannot be dispensed with, although it is far from necessary (boundary conditions on P should do). It is a variation of Example 3 and both are inspired by examples of Novshek and Sonnenschein (1979). The key requirement of the theorem, however, is that P be a continuous function. Examples 5

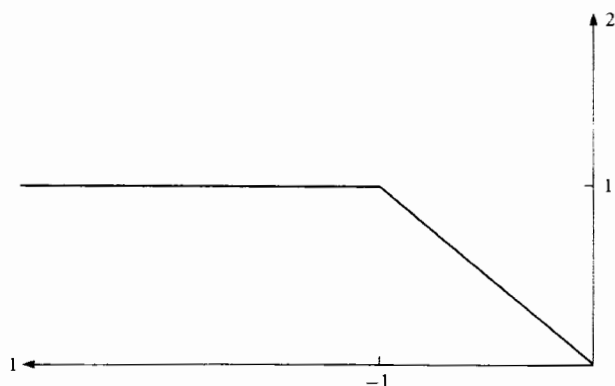

Figure 7.8

and 6 illustrate and discuss the economic significance of typical situations where y fails to be Walrasian (and Pareto optimal) on account of P not being a *globally* continuous function. They are, respectively, variations of examples due to K. Roberts (1980) and O. Hart (1980). In different ways their papers were first in putting a strong emphasis on the continuity condition.

Example 4. The consumption side is as in Example 3. There is again one type of firm with a production set as in Figure 7.8. In the economy \mathcal{E}_n there are $2n$ firms. Let $y_n: I_n \rightarrow \mathbb{R}^2$ be given by $y_n(i) = (-1, 1)$ for $1 \leq i \leq n$ and $y_n(i) = 0$ for $n < i \leq 2n$. Then y_n is bounded and does in fact converge to $y: [0, 1] \rightarrow \mathbb{R}^2$ defined by $y(i) = (-1, 1)$ for $1 \leq i \leq \frac{1}{2}$, $y(i) = 0$ for $i > \frac{1}{2}$. It is trivial to verify that, as in the previous example, y_n is a CN equilibrium. However, y is not a Walrasian equilibrium for the limit economy since at prices $(0, 1)$ total mean Walrasian supply must be 1 rather than $\frac{1}{2}$.

Example 5. There are two commodities. The first is the numeraire. There is one type of firm with production set $Y = \{v \in \mathbb{R}^2: -2 \leq v^1 \leq 0, 0 \leq v^2 \leq -2v^1, v^2 \leq 2\}$; see Figure 7.9. There are two types of consumers, owners and nonowners. Owners have initial endowments $(3, 0)$ and care only about the numeraire commodity. Nonowners have preferences and endowments (only of numeraire) that when combined display the offer curve Λ of Figure 7.10(a). Then, $J = \Lambda + \mathbb{R}_+^2 - \{(3, 0)\}$ and $P(z) = \{(1, q): p \in \xi(z^2)\}$, $\xi(z^2) = [2, \infty)$ for $z^2 = 0$, $\xi(z^2) = \{2\}$ for $z^2 < 1$, $\xi(z^2) = [1, 2]$ for $z^2 = 1$, $\xi(z^2) = \{1/z^2\}$ for $z^2 > 1$. See Figure 7.10(b). Economy \mathcal{E}_n has n firms. The Walrasian production vector of the limit

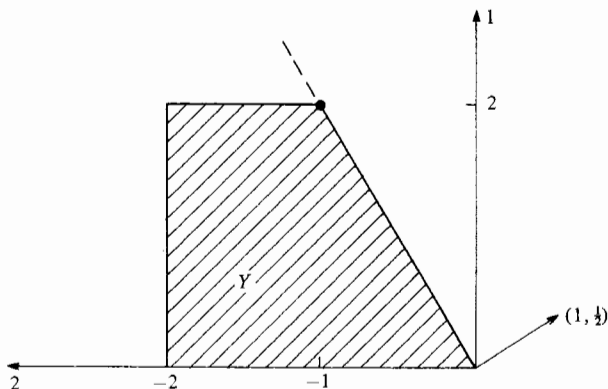

Figure 7.9

economy is $(-1, 2)$ with associated prices $(1, \frac{1}{2})$ and zero profits (see Figure 7.10(b)). The CN equilibria of \mathcal{E}_n depend on which price q we select from $\xi(1)$. Suppose that $q \geq 3/2$. Then in the economy \mathcal{E}_n it constitutes a CN equilibrium for each firm to produce $(-\frac{1}{2}, 1)$, so we have a sequence of CN equilibria that does not converge to Walrasian equilibrium. If $q < 3/2$, then a CN equilibrium for \mathcal{E}_n does not exist. Nevertheless, the qualitative characteristic of the example remains. Irrespective of the value selected from $\xi(1)$, there is always a sequence of approximate CN equilibria that remains bounded away from the Walrasian production.

Of course, the problem is the lack of a continuous selection from P . The example as described is nongeneric (i.e., a convenient perturbation will yield a P that is a continuous function), but this has merely been a matter of convenience of exposition. Figures 7.10(c) and (d) hint at how the example can be modified to get a robust one.

Example 6. There are three commodities. The third is the numeraire. There are two types of production sets (they are represented in Figure 7.11):

$$Y_1 = \{v \in R^3 : v^2 = 0, -2 \leq v^3 \leq 0, v^1 \leq 1, 0 \leq v^1 \leq -(5/6)v^3\}$$

$$Y_2 = \{v \in R^3 : v^1 = 0, -2 \leq v^3 \leq 0, v^2 \leq 1, 0 \leq v^2 \leq -(5/6)v^3\}$$

Let $J = \{z \in R^3 : 0 \leq z^1 \leq 1, 0 \leq z^2 \leq 1, z^3 \geq -5\}$ and note that $Y_1 + Y_2 \in J$. The price correspondence is given by $P(z) = \{(1, 2, 1)\}$ if $z^2 < z^1$, $P(z) = \{(2, 1, 1)\}$ if $z^1 < z^2$, $P(z) = \{(2 - \alpha, 1 + \alpha, 1) : 0 \leq \alpha \leq 1\}$ if $z^1 = z^2$. This P correspondence could be derived, for example, from a consumption

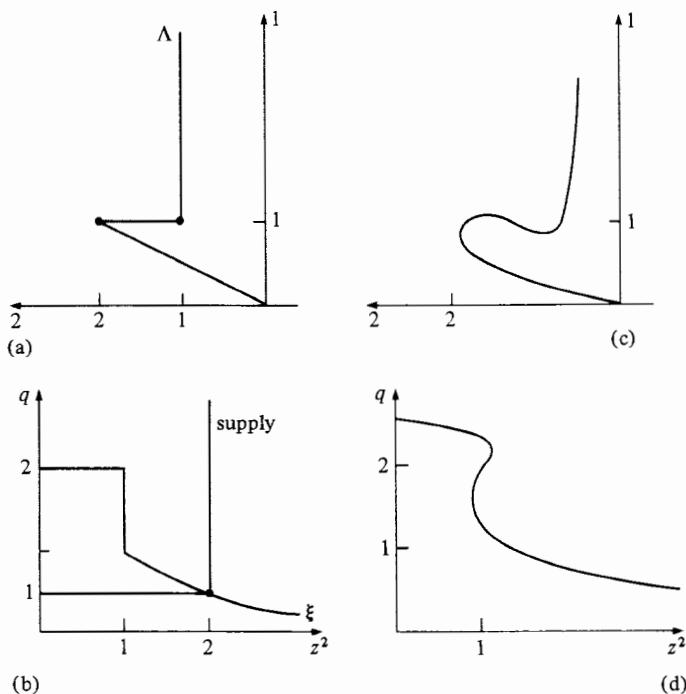

Figure 7.10

sector with two equal-weight consumer types. The first has utility function $u_1(z) = \min\{z^1 + 2z^2, 2z^1 + z^2\} + z^3$, endowment vector $(0, 0, 5)$ and consumption set R_+^3 . He receives no profits. The second has utility function $u_2(z) = z^3$, endowment vector $(0, 0, 5)$, consumption set R_+^3 and he receives all profits.

The economy \mathcal{E}_n is formed by n firms of each type. Then the unique Walrasian equilibrium production vector is $(1, 1, -12/5)$, which is sustainable by the price vector $(1.5, 1.5, 1)$. However, irrespective of the particular selection chosen from P , we have that $(0, 0, 0)$ is a CN equilibrium for \mathcal{E}_n because if $z^2 = 0$ and $z^1 > 0$, then the ruling price vector is $(1, 2, 1)$ and profits for Y_1 are negative, symmetrically for Y_2 . Note that there is no continuous selection from P . The example can be easily improved. Suppose that with reference to the consumption sector just described, we let the utility function of the first consumer be of the form $u_1(z) = v(z^1, z^2) + z^3$ where $v(z^1, z^2)$ is linear homogeneous and the unit isoquant of $v(z^1, z^2)$ coincides with the unit isoquant of $\min\{z^1 + 2z^2, 2z^1 + z^2\}$ except that the corner has been smoothed out.

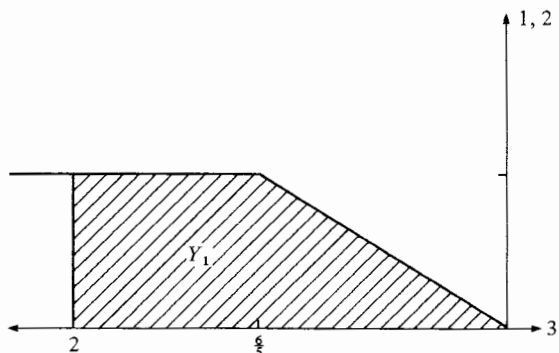

Figure 7.11

Then $P(z)$ will be a continuous function everywhere except at the origin. Nevertheless, the origin will still be a CN equilibrium for all n . Thus, there is nothing basically pathological about this example.

The economic meaning of this example (due to O. Hart (1980)) is obvious enough. If two commodities are complementary, some coordination in their production may be needed in order to guarantee optimality.

There is a parallel between the failure in this example and the failure in the models of Section 2. There we saw that the CN equilibrium notion did not embody the cooperation between buyers and sellers needed to activate a market. This same kind of degenerate failure does not happen in the model of this section: If given the trades in all other markets a particular market should be activated, it will. But it is quite possible, as this example illustrates, that the profitability of activating a market depends on some other markets being active. Thus, optimality may require a simultaneous move by several producers to activate several markets. This kind of coordination (involving, roughly speaking, more than two agents) is not captured in this model by the CN concept. Summing up: In the present model agents cooperate more than in the model in Section 1, and therefore the extreme failures of that model are avoided. In turn, to avoid the failures of the present one, it is necessary to bring more cooperation directly or indirectly among agents. For an examination of this issue from the point of the core, see Mas-Colell (1982).

3.6 *Approximating Walrasian by Cournot-Nash equilibria*

Here the problem converse to the one studied in the previous subsection takes the following form. Given $\mathcal{E}_n \rightarrow \mathcal{E}$ and a Walrasian equilibrium (y, q) for the limit economy \mathcal{E} , is there a price selection $p: J \rightarrow R^l$ (i.e.,

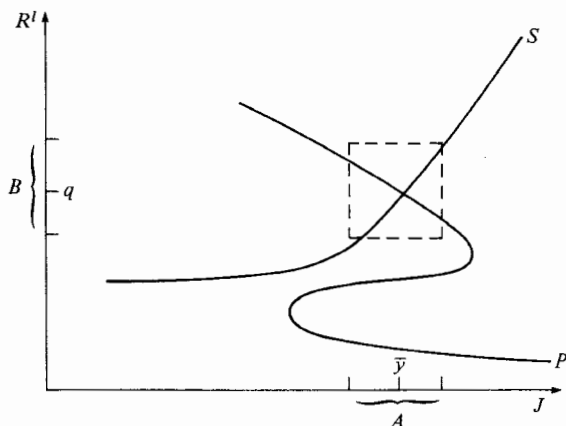

Figure 7.12

$p(z) \in P(z)$ for all $z \in J$) and a sequence $y_n \rightarrow y$ such that y_n is a CN production for ε_n with respect to p ?

Because for a sensible analysis the limit equilibrium we are starting with should not be just a fluke, we have to proceed as in Section 2 and develop a concept of regular Walrasian equilibrium. First, however, we will introduce two crucial conditions. Once they are available it will be entirely obvious how to formulate the hypothesis of regularity.

Condition U. Let $(y, q) \in J \times R^l$ be a Walrasian equilibrium for ε . We say that (y, q) satisfies Condition *U* (for unique value) if there are open (rel. to R^l) sets $A \subset J$, $B \subset R^l$ with $\bar{y} \in A$ and $q \in B$ such that (see Figure 7.12):

- (i) The graph of P restricted to $A \times B$ is the graph of a C^2 function $p: A \rightarrow R^l$;
- (ii) The supply correspondence S is a C^1 function on B .

Condition *U* says that in a neighborhood of the Walrasian equilibrium, supply must be a C^1 function of prices and that the requirement of continuity uniquely determines a local selection from P which, furthermore, is C^2 . In both cases differentiability is not of the essence but continuity is.

Let (y, q) be a Walrasian equilibrium satisfying Condition *U*. Take $B' \subset B$ such that $S(B') \subset A$. To define regularity it is natural to look at the C^1 map $G(v) = p(S(v)) - p$ from B into R^l . Of course, $G(q) = 0$ and any zero of G is a Walrasian equilibrium price vector. We say that (y, q) is a *Regular Walrasian Equilibrium* if condition *U* is satisfied and $\text{rank } DG(\bar{q}) = l$. This definition is due to K. Roberts (1980). If our P and

S correspondences derive from a general equilibrium economy with smooth aggregate excess demand, then the usual notion of regularity (maximal rank of the Jacobian matrix of excess demand at equilibrium prices) translates into the condition: $\text{rank } DG(\bar{q}) = l$. Thus, it is to be noted that our regularity concept here is stronger because of the first part of Condition U , which is not implied by the usual notion (the second part would, of course, be automatically satisfied). Nevertheless, this stronger concept of regular economy can still be proved to be generic in the appropriate sense.

The following theorem is due to K. Roberts (1980).

Theorem 4. Let each Y_h be bounded below. Suppose that $\mathcal{E}_n \rightarrow \mathcal{E}$ and (y, q) is a regular Walrasian equilibrium for \mathcal{E} . Then there is a price selection $p: J \rightarrow R^l$ continuous at \bar{y} and with $p(\bar{y}) = q$, a $N > 0$ and a sequence $y_n \rightarrow y$, $n > N$, such that y_n is a CN production for \mathcal{E}_n with respect to $p(\cdot)$. As with Theorem 2 we could also assert that each such y_n is symmetric (i.e., identical firms carry out identical productions).

Example 7 shows that the boundedness below of Y_h cannot be dispensed with. Examples 8 and 9 do the same for the first part of Condition U (whose importance was already perceived in a related context by Roberts and Postlewaite (1974)). Example 10 takes care of the second part. As we describe them, we shall comment on their economic significance (or lack of it). A feature common to all of them is worth noting. Every example takes place in an economy where Theorem 3 also fails. Although this is not absolutely general, it is not coincidental either. Indeed, suppose that the Walrasian equilibrium of the limit is unique. If there are forces that prevent it from being approachable by CN equilibria (failure to Theorem 4), then every convergent sequence of CN equilibria will have to converge to a non-Walrasian limit (failure to Theorem 3). Example 7 is due to Novshek and Sonnenschein (1979). Example 8 has been used in a related context by Makowski (1980) and Mas-Colell (1981).

As with Theorem 2, Theorem 4 contains an existence result. This is noteworthy since, in contrast to the model in Section 1, there is no expectation that an equilibrium will exist in an arbitrary finite economy. Nevertheless, Theorem 4 guarantees that if a finite economy is near enough a continuum economy exhibiting at least one regular Walrasian equilibrium, then a CN equilibrium will exist.

Example 7. Take the economy of Example 3. At the Walrasian equilibrium of \mathcal{E} the (mean) input use $-\bar{y}^1$ is less than 1. See Figure 7.13. If y_n is a CN production for \mathcal{E}_n , then $-\bar{y}_n^1 = -1$, because otherwise it would

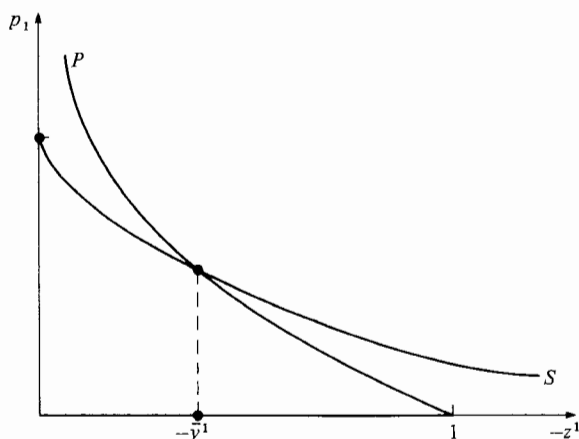

Figure 7.13

always pay any firm to exhaust input availability, bringing its price down to zero. So, the Walrasian equilibrium cannot be approached. It is clear from Figure 7.13 that the equilibrium is regular. What goes wrong is that Y is not bounded. This example looks very pathological. It should help emphasize a point already made in Section 3.4 that the refined way to proceed would be to exploit boundary conditions on P . For Theorem 4 the boundedness away from zero and infinity of the values of $P(z)$ would do.

Example 8. This example illustrates the inadequacy of the model specification of this section for market situations where the strategically active agents do not face a passively adapting group (and, by continuity, where this adapting group is thin). The market in question will be one for a purely intermediate good.

There are three commodities and two types of production sets:

$$Y_1 = \{v \in R^3 : v^2 \leq -v^1, v^1 \leq 0, v^3 \leq 0\}$$

$$Y_2 = \{v \in R^3 : v^3 \leq -v^2, v^2 \leq 0, v^1 \leq 0\}$$

Agents care only about commodity 3, which is taken to be the numeraire. There is no need to distinguish among owners and nonowners. Each agent has endowments $(1, 0, 0)$. Note that commodity 2 is purely intermediate. Then $J = \{v : v^1 \geq -1, v^2 \geq 0, v^3 \geq 0\}$ and $P(z) = \{(1, 0, 1)\}$ for $v^2 > 0$, $P(z) = \{(1, q, 1) : q \in R_+\}$ for $v^2 = 0$. The Walrasian equilibrium aggregate production is $\bar{y} = (-1, 0, 1)$ and the Walrasian price vector is $\bar{p} = (1, 1, 1)$. Now let $\mathcal{E}_n \rightarrow \mathcal{E}$, where \mathcal{E}_n is obtained by replication. Sup-

pose that y_n is a CN equilibrium for ε_n . Then $\bar{y}_n^2=0$ because $\bar{y}_n^2 < 0$ is incompatible with $\bar{y}_n \in J$ and if $\bar{y}_n^2 > 0$, then the firms of type 1 would make losses. If $\bar{y}_n^3 > 0$, then some firm of type 2 is consuming a nonzero amount of good 2. Because someone is producing it, its price cannot be zero, but by contracting consumption by ε the firm can make the price of good 2 fall to zero and so increase its profits. Therefore, at a CN equilibrium $\bar{y}_n^3=0$, and we conclude that \bar{y} cannot be approached. Clearly, if we introduce a bit of curvature in the boundary of Y_1, Y_2 and also bound below both sets, the nonapproachability of \bar{y} remains. Thus, the source of the problem is the inexistence of a continuous selection of P through (\bar{p}, \bar{y}) , that is, the failure of part (i) of Condition U .

Example 9. Example 8 illustrated how extreme complementarities in aggregate production led to the failure of the first part of Condition U and of Theorem 4. This example will do the same for complementarities in consumption. Both examples should serve to emphasize the point already hinted at in the discussion of Example 6, namely, that a strict individualistic viewpoint is ill-suited to analyze economic situations with extreme forms of complementarities.

The economy is the same as in Example 6. Suppose that some price selection is given and that as $n \rightarrow \infty$, the Walrasian equilibrium can be approximated by a sequence of CN equilibria. Let z_n be the corresponding CN aggregate productions. Then $z_n \rightarrow (1, 1, -(12/5))$. So, eventually $z_n^1 > 0$ and $z_n^2 > 0$. Therefore, $z_n^1 = z_n^2$ because at a CN equilibrium the profits of every firm must be nonnegative. But we claim that a situation where $z_n^1 = z_n^2$ cannot be in equilibrium. Indeed, whichever $p \in P(z_n)$ has been selected we have that either $p^1 < 2$ or $p^2 < 2$. Let $p^1 < 2$. Take any firm producing a positive amount of the first good and decrease production by ε . The price of the first commodity will then be 2 and profits will increase. Hence, no such sequence of CN equilibria exists. Observe that the features of the example remain if we give some curvature to the boundary of the production set. What fails is the existence of a continuous selection from P in a neighborhood of the Walrasian productions. It should be noted that the failure of the example is more degenerate (i.e., less generic) than the failure of Example 6. Here the situation can be remedied by smoothing out the corners of the indifference curves in a neighborhood of the Walrasian equilibrium. There the example remains as long as preferences are kept homothetic.

Example 10. This example will illustrate the need of the second part of Condition U . We have $l=2$ with the first commodity being the numeraire. There is only one type of production set $Y = \{v \in R^2 : v^2 \leq 3,$

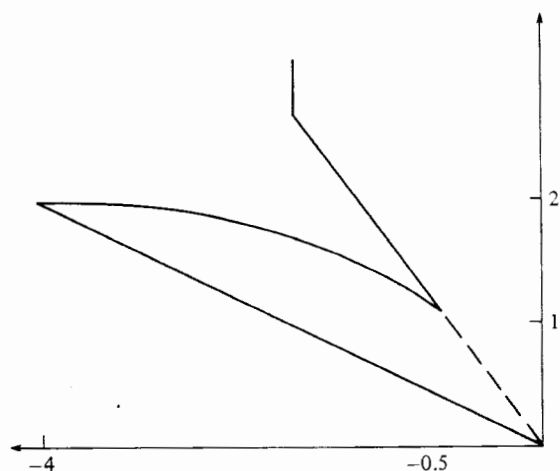

(a)

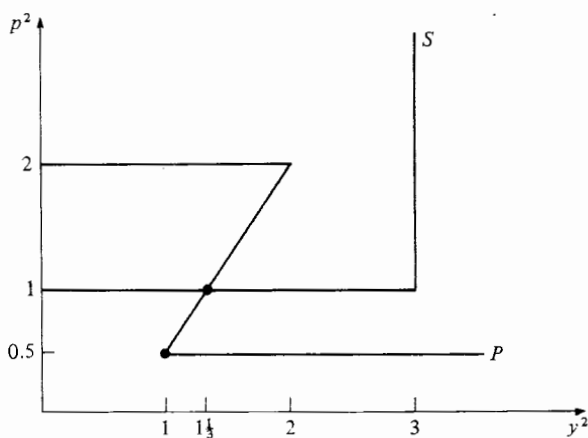

(b)

Figure 7.14

$v^2 \leq -v^1$, $-3 \leq v^1 \leq 0$ }. As usual the consumption sector is formed by owners (who have endowments and care only about the numeraire) and nonowners. These have the excess demand function indicated in Figure 7.14(a), which generates the P correspondence of Figure 7.14(b). The Walrasian equilibrium has a production vector $\bar{y} = (-1 - \frac{1}{3}, 1 + \frac{1}{3})$ and price vector $(1, 1)$. By replication one obtains the sequence \mathcal{E}_n . Suppose

that y_n is a sequence of CN equilibria with respect to a selection $p(\cdot)$ which is continuous at \bar{y} and has $p(\bar{y}) = (1, 1)$. Given the P under consideration, this implies that $p(\cdot)$ is increasing in a neighborhood of \bar{y} . Suppose that $\bar{y}_n \rightarrow \bar{y}$. Then $\bar{y}_n \neq 0$ and therefore $p(\bar{y}_n) \geq 1$ (firms cannot make losses at the CN equilibrium). But then any firm not producing at capacity (and there have to be some because $\bar{y}_n \rightarrow \bar{y}$) has an incentive to expand production by ϵ because unit cost remains unaltered but the price increases, which contradicts the hypothesis that \bar{y}_n is a CN equilibrium.

The example remains if the P correspondence is smoothed out provided it is upward sloping at the Walrasian equilibrium. We want to emphasize, however, that it is not the (nondegenerate) upward sloping demand that makes the example but the flatness (strict constant returns in this case) at equilibrium productions of the individual production set. Novshek and Sonnenschein (1978) have investigated limit situations with aggregate strict constant returns to scale but nonconvex individual production sets.

4 Proofs

For ease of presentation we will prove Theorem 2 before Proposition 1 and Theorem 1.

4.1 Proof of Theorem 2

The proof will proceed in four steps. Although it may appear long, its general structure is quite clear. The strategy pursued is to find, for the "right" dimension s (which turns out to be $2l-1$), C^1 maps G_n, G from some open set $V \subset R^s$ into R^s that have the properties: (i) the zeros of G (i.e., the solutions to $G(v) = 0$) yield the Walrasian solutions of \mathcal{E} , the particular regular equilibrium we are focusing upon being one of the solutions (typically the only one in V); (ii) the zeros of G_n yield the Cournot-Nash solutions for \mathcal{E}_n ; (iii) G_n converges to G C^1 uniformly on V . We then obtain our approximating sequence in a straightforward manner via the implicit function theorem. The situation is pictured in Figure 7.15. The key aspect to note is that in spite of the number of agents of the economies \mathcal{E}_n going to infinity, the maps G_n, G are all defined in a space of the same fixed dimension. Once this has been accomplished, the rest follows rather simply. We remark that the fixed dimension of the domain of G and the G_n 's is $2l-1$, which is also independent of the number of types. In fact, our proof does not depend in any essential way on the finiteness of P . It can be extended without the slightest difficulty to the case where P is merely "compact."

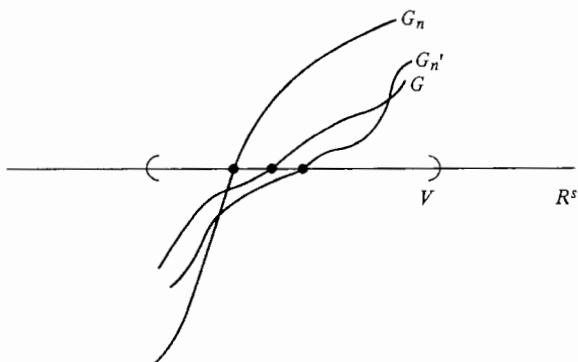

Figure 7.15

In Step 1 we construct the function G . Steps 2, 3, 4 build G_n . Actually, this is done in Step 4; Steps 2 and 3 are preparatory. Step 4 also carries out the application of the implicit function theorem.

Step 1. Let $\bar{p} \in R_{++}^{l-1}$ be the given regular Walrasian equilibrium price. Let $U \subset R_{++}^{l-1}$ be a small connected neighborhood of \bar{p} on which Condition H is satisfied.

Define $\xi : U \rightarrow R_{++}^{2l-1}$ by

$$\xi(p) = (p^1 d^1(p), \dots, p^{l-1} d^{l-1}(p), d^l(p), s^1(p), \dots, s^{l-1}(p))$$

To each p , ξ assigns the Walrasian vector of aggregate bids (denominated in numeraire units) and offers. We drop $s^l(p)$ because it can be derived from the other entries of the vector, that is, $s^l(p) = d^l(p) - \sum_{j=1}^{l-1} p^j f^j(p)$. Denote $\bar{z} = \xi(\bar{p})$. Those are the Walrasian equilibrium aggregate bids and offers. Note that ξ is a C^1 function.

Define $\pi : R_{++}^{2l-1} \rightarrow R_{++}^{l-1}$ by $\pi(z) = ((z^1/z^{l+1}), \dots, (z^{l-1}/z^{2l-1}))$. Given bids and offers z , $\pi(z)$ is to be thought as a vector of clearing prices. Note that in particular, $\pi(\bar{z}) = \bar{p}$ because $d^j(\bar{p}) = s^j(\bar{p})$ for all j .

Let $V \subset R_{++}^{2l-1}$ be a neighborhood of \bar{z} such that $\pi(V) \subset U$. Define then $G : V \rightarrow R^{2l-1}$ by $G(z) = \xi(\pi(z)) - z$. Observe that $G(z) = 0$ implies that $p = \pi(z)$ is a Walrasian equilibrium price because then for every j , $z^j = p^j d^j(p)$, $z^{l+j} = s^j(p)$ and $p^j = z^j / z^{l+j}$ which yields $d^j(p) = s^j(p)$. Conversely, if $f(p) = 0$ and $z = \pi(p) \in V$, then $G(z) = 0$ (in particular, $G(\bar{z}) = 0$). So, there is a natural one-to-one correspondence between the zeros of f and the zeros of G . The interpretation of the function G is simple enough. Given a vector of (aggregate) bids and offers z , $\xi(\pi(z))$ is the vector of optimal ("notional") Walrasian aggregate bids and

offers corresponding to the clearing prices $\pi(z)$. If they coincide with the z with which we started, we have an equilibrium.

It is clear enough that, being the equilibria in correspondence, we should expect that their regularity will also be.

Lemma 1. $Df(\bar{p})$ is nonsingular if and only if $DG(\bar{z})$ is nonsingular.

Proof. Of course, $\text{rank} f(\bar{p}) = l - 1$ if and only if

$$\text{rank}(Dd'(\bar{p}) - Ds'(p)) = l - 1,$$

where d', s' are the functions obtained from d, s by dropping the last coordinate. Consider the map $\pi(\xi(p)) - p$ with values in R_{++}^{l-1} and domain $U \subset R_{++}^{l-1}$. Of course, $\pi(\xi(\bar{p})) - \bar{p} = 0$. Denote by E the $(l-1) \times (l-1)$ diagonal matrix with generic entry $e_{jj} = \bar{p}^j / s^j(\bar{p}) \neq 0$. A simple computation yields $D(\pi(\xi(\bar{p})) - \bar{p}) = E(Dd'(\bar{p}) - Ds'(\bar{p}))$. Therefore, $Df(\bar{p})$ is nonsingular if and only if $D(\pi(\xi(\bar{p})) - \bar{p})$ is nonsingular. Let A be the $(2l-1) \times (l-1)$ matrix $D\xi(\bar{p})$ and B the $(l-1) \times (2l-1)$ matrix $D\pi(\bar{z})$. Then $D(\pi(\xi(\bar{p})) - \bar{p}) = BA - I$. On the other hand, $DG(\bar{z}) = D(\xi(\pi(\bar{z})) - \bar{z}) = AB - I$. But $\text{rank}(AB - I) = l - 1$ if and only if $\text{rank}(BA - I) = l - 1$ (Proof: Let $(AB - I)v = 0, v \neq 0$. Then $w = Bv \neq 0$ and $(BA - I)w = 0$, which yields the desired conclusion.)

Step 2. In this step we consider a fixed type h . To save on notation we drop all subindexes h . Let $u : R_+^l \rightarrow R$ be a C^2 utility function for \succeq with no critical point.

The sets $U \subset R_{++}^{l-1}, V \subset R_{++}^{2l-1}$ and the vectors \bar{p}, \bar{z} are as in Step 1. Let $\bar{x} \in R^l$ be the vector: $\bar{x}^j = f_h^j(\bar{p})$ for $j \leq l-1, \bar{x}^l = -\bar{p} f_h(\bar{p})$. That is to say, \bar{x} is the Walrasian equilibrium excess demand vector of type h . By assumption, $\bar{x} \gg -\omega$ and $\bar{x}^j \neq 0$ for all $j \leq l$. Let $J \subset R^l$ be a neighborhood of \bar{x} with the properties: (i) $x + \omega \gg 0$ for all $x \in J$, (ii) $x^j \bar{x}^j > 0$ for all $j \leq l$ and $x \in J$, (iii) J is bounded, that is, there is $\epsilon > 0$ such that $\epsilon |x^j| < 1$ for all $x \in J$ and $j \leq l$.

Define a function $\eta : V \times (-\epsilon, \epsilon)^l \times J \rightarrow R^l$ by:

$$\eta^j(z, q, x) = \begin{cases} \frac{z^j}{z^{l+j}} (1 + q^j x^j) & \text{if } x^j < 0 \\ \frac{z^j}{z^{l+j}} \left(\frac{1}{1 - q^j x^j} \right) & \text{if } x^j > 0 \end{cases}$$

If we convene that $z^{2l} = z^l, \eta^l$ is also well-defined. The function η is C^1 . Observe that $\eta(z, 0, x)$ is the vector of clearing prices associated to z .

Hence, because \bar{x} are the Walrasian demands associated with \bar{z} and $\bar{x} + \omega \gg 0$ we have that for some $\bar{\lambda} \neq 0$: $\eta(\bar{z}, 0, \bar{x}) - \bar{\lambda} \partial u(\bar{x}) = 0$, and $\sum_{j=1}^{l-1} (\bar{z}^j / \bar{z}^{l+j}) \bar{x}^j + \bar{x}^l = 0$. Therefore, $(\bar{z}, 0, \bar{x}, \bar{\lambda})$ satisfies the system of $l+1$ equations:

$$\begin{aligned} \eta(z, q, x) - \lambda \partial u(x) &= 0 \\ \sum_{j=1}^{l-1} \frac{z^j}{z^{l+j}} x^j + x^l &= 0 \end{aligned}$$

At $(\bar{z}, 0, \bar{x}, \bar{\lambda})$ the Jacobian of this system with respect to the $(l+1)$ variables (x, λ) is

$$\begin{vmatrix} -\partial^2 u(\bar{x}) & -\partial u(\bar{x}) \\ (\bar{p}^T, 1) & 0 \end{vmatrix} = (-1)^{l+1} \bar{\lambda} \begin{vmatrix} \partial^2 u(\bar{x}) & \partial u(\bar{x}) \\ (\partial u(\bar{x}))^T & 0 \end{vmatrix} \neq 0$$

because of the nonzero curvature condition. Therefore, by the implicit function theorem (see, for example, Schwartz (1967)), there are $\bar{z} \in V' \subset V$, $0 < \epsilon' < \epsilon$, and C^1 functions $x(z, q)$, $\lambda(z, q)$ defined on $V' \times (-\epsilon', \epsilon)'$ such that: $\eta(z, q, x(z, q)) - \lambda(z, q) \partial u(x(z, q)) = 0$ and

$$\sum_{j=1}^{l-1} \frac{z^j}{z^{l+j}} x^j(z, q) + x^l(z, q) = 0$$

for all $(z, q) \in V' \times (-\epsilon', \epsilon)'$. Furthermore, for a neighborhood $J' \subset J$ of \bar{x} , we have that given z, q the only solution x to the system of equations with $x \in J'$ is $x(z, q)$. Because to begin with V, J , and ϵ can be chosen arbitrarily small we will, to save notation and without loss of generality, identify V', J', ϵ' with V, J, ϵ . The interpretation of $x(z, q)$ is clear. For $q=0$, $x(z, 0) = \hat{f}_h(\pi(z))$ is nothing but the Walrasian demand function (composed with π). In general, therefore, $x(z, q)$ is a kind of Walrasian demand with distortions (preventing full proportionality of prices and marginal utilities). The latter are represented by the vector q .

From now on V and ϵ will be as in the end of this step. For each type h we have a $x_h(z, q)$. There is no loss of generality if we take all the $x_h(z, q)$ to be defined on $V \times (-\epsilon, \epsilon)'$. The range is contained in $J_h \subset R^l$. Remember that $x_h + \omega_h \gg 0$ for all $x_h \in J_h$.

Step 3. In this step we shall consider a fixed $\mathcal{E}_n: I_n \rightarrow P$. It will be convenient to represent bid, offer, and net trade functions as vectors: $m = (m_1, \dots, m_n) \in R_+^{ln}$, $y = (y_1, \dots, y_n) \in R_+^{ln}$, $x = (x_1, \dots, x_n) \in R^{ln}$. The subscript i denotes an agent.

For each i , let $u_i: R_+^l \rightarrow R$ be the utility function chosen in the previous step for the type of preferences of the i th agent.

We let $V \subset R^{2l-1}$ be as at the end of Step 2. It shall be convenient to define the cone $V' \subset R^{2l}$ as $V' = \{z \in R^{2l} : \alpha(z^1, \dots, z^{2l-1}) \in V \text{ for some } \alpha > 0 \text{ and } z^{2l} = z^l\}$.

Suppose that $(z, x) \in V' \times R^{ln}$ satisfies:

$$(a) \quad \begin{aligned} z^j &= \frac{z^j}{z^{l+j}} \sum_i \max\{0, x_i^j\} \\ z^{l+j} &= \sum_i \max\{0, -x_i^j\} \end{aligned} \quad \text{for all } j$$

This is a kind of balance of demand and supply condition. Then if we define $(m, y) \in R^{2ln}$ by $m_i^j = (z^j/z^{l+j}) \max\{0, x_i^j\}$, $y_i^j = \max\{0, -x_i^j\}$ for all j , we immediately see that $x[m, y] = x$ where $x[m, y]$ is the net trade generated according to the rules of the trading game. Thus, if a pair of aggregate bid and offer vector z and net trade vector x satisfies the balancedness Condition (a), then compatible individual bids and offers vectors can be generated in the natural manner. We say that (m, y) corresponds to (z, y) .

For each i , we now define an important auxiliary function $F_i: Q_i \rightarrow R^l$, $Q_i = \{(z, x_i) \in V' \times R^l : x_i^j > -z^{l+j} \text{ for all } j\}$ by:

$$F_i(z, x_i) = \begin{cases} \frac{x_i^j}{z^{l+j}} \left(1 + \frac{x_i^j}{z^{l+j}}\right) & \text{if } x_i^j < 0, \\ \frac{z^j}{z^{l+j}} \left(\frac{1}{1 - (x_i^j/z^{l+j})}\right) & \text{if } x_i^j > 0 \end{cases}$$

Given $(z, x) \in V' \times R^{ln}$ we state three more conditions on (z, x) :

- (b) for each i , $x_i \geq -\omega_i$;
- (c) for each i , $\sum_{j=1}^l (z^j/z^{l+j})x_i^j = 0$;
- (d) for each i , $x_i \in Q_i$ and $F_i(z, x_i) = \lambda_i \partial u_i(x_i)$ for some λ_i .

Lemma 2. Let $(\hat{z}, \hat{x}) \in V' \times R^{ln}$ satisfy (a), (b), (c), and (d). Then \hat{x} is a CN net trade. The bids and offers vector $(\hat{m}, \hat{y}) \in R^{2ln}$ that correspond to (\hat{z}, \hat{x}) are the CN equilibria.

Proof. Condition (c) is the budget constraint. So, Condition (b) gives individual feasibility. We only need to verify the preference maximization condition.

Take an agent i . It will remain fixed for the rest of this proof. Denote $\bar{m} = \sum_{i' \neq i} \hat{m}_{i'}$, $\bar{y} = \sum_{i' \neq i} \hat{y}_{i'}$. By definition of (\hat{m}, \hat{y}) we have:

$$\text{if } \hat{x}_i^j < 0, \text{ then } \bar{m}^j = \hat{z}^j \text{ and } \bar{y}^j = \hat{z}^{l+j} + \hat{x}_i^j$$

(*)

$$\text{if } \hat{x}_i^j \geq 0, \text{ then } \bar{m}^j = \hat{z}^j - \frac{\hat{z}^j}{\hat{z}^{l+j}} \hat{x}_i^j = \hat{z}^j \left(\frac{\hat{z}^{l+j} - \hat{x}_i^j}{\hat{z}^{l+j}} \right)$$

$$\text{and } \bar{y}^j = \hat{z}^{l+j}$$

Let $g(x_i) = \sum_{j=1}^l [\bar{m}^j / (\bar{y}^j - x_i^j)] x_i^j$. Note that $g(\hat{x}_i) = 0$ (use (*) and (b)). We saw in Section 2.2 that the constraint set of agent i in net trade space is $\{x_i \in R^l : g(x_i) \leq 0, -\omega_i \leq x_i < \bar{y}\}$. The shape of this set and its frontier (i.e., $g(x_i) = 0$) is pictured in Figure 7.2. At any $x_i < \bar{y}$, $\partial_j g(x) = \bar{m}^j \bar{y}^j / (\bar{y}^j - x_i^j)^2$ and $\partial_{jj} g(x) = [2\bar{m}^j \bar{y}^j / (\bar{y}^j - x_i^j)^3] > 0$. Hence, $\partial^2 g(x_i)$, which is diagonal, is positive definite, and we conclude that g is convex in the domain $x_i > \bar{y}$. Therefore, $\partial g(\hat{x}_i)(\hat{x}_i - x_i) \geq 0$ whenever $g(x_i) \leq 0$ and $x_i > \bar{y}$ (remember that $g(\hat{x}_i) = 0$). This implies that in order to guarantee preference maximization it will suffice to show that, for some $\lambda_j > 0$, we have $\partial g(\hat{x}_i) = \lambda_j \partial u_i(\hat{x}_i)$; see Figure 7.2. This follows from Condition (b) if we show $\partial g(\hat{x}_i) = F_i(\hat{z}, \hat{x}_i)$.

We have $\partial_j g(\hat{x}_i) = \bar{m}^j \bar{y}^j / (\bar{y}^j - \hat{x}_i^j)^2$. Using (*) this yields:

- (i) if $\hat{x}_i^j < 0$, then $\partial_j g(\hat{x}_i) = [\hat{z}^j / (\hat{z}^{l+j})^2] (\hat{z}^{l+j} + \hat{x}_i^j) = F_i^j(\hat{z}, \hat{x}_i)$
- (ii) if $\hat{x}_i^j \geq 0$, then

$$d_j g(\hat{x}_i) = \bar{m}^j \hat{z}^{l+j} / (\hat{z}^{l+j} - \hat{x}_i^j)^2 = (\hat{z}^j / \hat{z}^{l+j}) [\hat{z}^{l+j} / (\hat{z}^{l+j} - \hat{x}_i^j)] = F_i^j(\hat{z}, \hat{x}_i).$$

This ends the proof of the lemma.

A warning may be in order. The vector $F_i(z, x_i)$ does not generally represent the gradient of the frontier of the attainable region of agent i at the point x_i . This is the case only at equilibrium, that is, when the demand = supply Condition (a) is satisfied.

Step 4. In this step we put together the two previous ones, define the functions $G_n : V \rightarrow R^{2l-1}$ and apply the implicit function theorem.

For \mathcal{E}_n denote by θ_n^h the fraction of agents of type h . Of course, $\theta_n^h \rightarrow \theta^h$.

Interpreting $z_n \in V$ as mean aggregate bids and offers we know from Step 3 that $z_n \in V$ and $(x_{1n}, \dots, x_{mn}) \in R^{ln}$ yield a symmetric CN equilibrium if the following conditions are fulfilled (put $z_n^{2l} = z_n^l$):

- (a)
$$z_n^j = \frac{z_n^j}{z_n^{j+l}} \sum_h \theta_n^h \max\{0, x_{hn}^j\}$$
 for $1 \leq j \leq l$
- $$z_n^{j+l} = \sum_h \theta_n^h \max\{0, -x_{hn}^j\}$$
- (b)
$$x_{hn} \geq -\omega_h \text{ for all } h$$

$$(c) \quad \sum_{j=1}^l \frac{z_n^j}{z_n^{l+j}} x_{hn}^j = 0 \quad \text{for all } h$$

$$(d) \quad x_{hn} \in Q_h \quad \text{and} \quad F_h(nz_n, x_{hn}) = \lambda_h u_h(x_{hn}), \quad \lambda_h > 0 \quad \text{for all } h$$

Let N be such that, for all $l+1 \leq j \leq 2l$ and $z \in V$, $Nz^j > 1/\epsilon$ where ϵ is as in Step 2 and we convene that $z^{2l} = z^l$. For any $z \in V$ define $q_n(z) \in (-\epsilon, \epsilon)^l$ by $q_n^j(z) = 1/z^{l+j}$.

Observe that, by definition, if $z \in V$, $x_{hn} \in J_h$ and $n > N$, then $x_{hn} \in Q_h$ and $F_h(nz_n, x_{hn}) = \eta_h(z_n, q_n(z_n), x_{hn})$. Therefore, Conditions (b), (c), and (d) will be satisfied by any $z_n \in V$ and the corresponding

$$x_{hn}(z_n, q_n(z_n)) \equiv x_{hn}(z_n), \quad 1 \leq h \leq m.$$

Note then that for any $z \in V$, $x_{hn}(z) \rightarrow \hat{f}_h(\pi(z))$. In fact, taking a smaller V if necessary, we can assume that $x_{hn}: V \rightarrow R^{l-1}$ converges to $\hat{f}_h \circ \pi$, C^1 uniformly.

Therefore, $\bar{z}_n \in V$ and $x_{hn}(\bar{z}_n)$, $1 \leq h \leq m$, $n > N$, will generate a symmetric CN equilibrium if Condition (a) is also satisfied, that is, if \bar{z}_n is a zero of the function $G_n: V \rightarrow R^{2l-1}$ defined (with the usual convention $z^{2l} = z^l$) by:

$$G_n^j(z) = \frac{z_n^j}{z_n^{j+l}} \sum_h \theta_n^h \max\{0, x_{hn}^j(z_n)\} - z_n^j, \quad 1 \leq j \leq l$$

$$\sum_h \theta_n^h \max\{0, -x_{hn}^j(z_n)\} - z_n^j, \quad 1 \leq j \leq l-1$$

It is clear that G_n converges to G , defined in Step 1, C^1 uniformly on V . Also, if $z_n \rightarrow z$, then for each h , $x'_{hn}(z_n) \rightarrow f_h(\pi(z))$. Therefore, we can reduce the search for a suitable sequence of symmetric CN equilibria to the search for a sequence $z_n \rightarrow \bar{z}$ with $G(z_n) = 0$. The existence of a $N' \geq N$ and such a sequence for $n > N'$ is a consequence of the implicit function theorem. The following version of it will do (put first $G = G_\infty$, then let $M = \{\infty, 1, 2, \dots\}$, $d(n, m) = |(1/n) - (1/m)|$ and interpret $G(z, t) = G_t(z)$).

Implicit function theorem (see Schwartz (1967), ch. 3.8): Let $V \subset R^s$ be an open set and M a metric space. Let $G: V \times M \rightarrow R^s$ be continuous. Suppose that $D_z G(z, t)$ exists and depends continuously on (z, t) for all $(z, t) \in V \times M$. Suppose that $G(\bar{z}, \bar{t}) = 0$ and $D_z G(\bar{z}, \bar{t})$ is nonsingular. Then there are neighborhoods $\bar{z} \in V' \subset V$, $\bar{t}' \in M' \subset M$ and a continuous function $z: V' \rightarrow M'$ such that $G(z(t), t) = 0$ for all $t \in M'$. Further, $G(z, t) = 0$, $(z, t) \in V' \times M'$ implies $z = z(t)$.

One observation is in order. Strictly speaking, we have shown the

existence and uniqueness of the approximating sequence only within the class of symmetric net trades. A careful reading of the proof (especially Step 4) will reveal, however, that uniqueness holds in general. Basically, one only has to systematically replace the subindex h by i . The functions G_n , G will still be perfectly well-defined on the space R^{2l-1} .

4.2 Proof of Proposition 1

The proof is unavoidably technical. Let $r > \omega_h^j$ for all j and h . We proceed by contradiction. Let x_n be a sequence of CN net trade equilibria for $\mathcal{E}_n: I_n \rightarrow P$. The corresponding aggregate bids and offers are z_n . It suffices to establish that

$$\max_{i \in I_n} |x_n^l(i)| \rightarrow \infty$$

does not hold. Suppose it does, then $z_n^{2l} \rightarrow \infty$ and we can assume $z_n^{2l} \geq 2r$. Call $p_n^j = z_n^j / z_n^{l+j}$ and normalize $\sum_j p_n^j = 1$. Because for all j , x_n^j is uniformly bounded below by $-r$, we should have $p_n^l \rightarrow 0$. We can also assume (extract a subsequence if necessary and relabel) that $p_n^1 > (1/l)$ for all n . The following properties are not difficult to verify (the uniform boundedness below of x_n is again the crucial fact): $\#\{i: |x_n^j(i)| \leq r, \text{ all } j\} \geq (n/2)$, there is $\epsilon > 0$ such that $\#\{i: x_n^1(i) + \omega_n(i) \geq \epsilon\} \geq \epsilon n$ and $\#\{i: 2x_n^1(i) \leq -z_n^{l+1}\} \geq n-2$. We can therefore assume that there is a sequence i_n and $v \in R^l$ such that $\mathcal{E}(i_n)$ is of the same type (say h) for all n , $v_n \equiv x_n(i_n) \rightarrow v$, $v_n^1 + \omega_h^1 > \epsilon$ and $2v_n^1 \geq -z_n^{l+1}$. Let now $q_n = dg(v_n)$, where g is the equation for the frontier of the attainable set of i_n in the economy \mathcal{E}_n (see Figure 7.2). As in the proof of Lemma 2 (in Step 3 of the proof of Theorem 2) we have that if $v_n^j < 0$, then $q_n^j = p^j [1 + v_n^j / z_n^{l+j}]$ and if $v_n^j \geq 0$, then $q_n^j = p_n^j [1 / (1 - (v_n^j / z_n^{l+j}))]$. Therefore, $q_n^1 \geq (1/2)p_n^1 \geq (1/2l)$, $q_n^l \leq 2p_n^l$, and we conclude $q_n^l / q_n^1 \rightarrow 0$. Define $w_n \in R^n$ by $w_n^1 = -q_n^l / q_n^1$, $w_n^j = 0$ for $1 < j < l$, $w_n^l = 1$. Then, for n sufficiently large, $\omega_h + v_n + w_n \geq 0$ and therefore $\omega_h + v_n \succeq_h \omega_h + v_n + w_n$ (because $q_n w_n = 0$ and \succeq_h is a convex preference relation). By continuity of \succeq_h , $\omega_h + v \succeq_h \omega_h + v + w$, where $w_n \rightarrow w$. But this contradicts the strict monotonicity of \succeq_h because $w \geq 0$ and $w \neq 0$. This contradiction establishes the proposition.

4.3 Proof of Theorem 1

Part (i) is a trivial consequence of Proposition 1 and the fact that a bounded set of measures on a compact metric space (in this case, K) is relatively compact. So, any sequence of such measures (in our case the μ_{nh} , $1 \leq h \leq m$) has a convergent subsequence. Because, in turn, any

limit measure μ_h satisfies $\mu_h(K) = \lambda(I_h)$, it can be generated by a function $x_h : I_h \rightarrow R^l$.

The proof of Part (ii) is at this point very simple, the intuition for it being quite obvious: If aggregate bids and offers go to infinity, then no individual trader can seriously affect the prices at which he trades.

If $A = \phi$, then the claim follows vacuously. Let $A \neq \phi$ and denote by z_n the aggregate bids and offers underlying x_n . Clearly, $z_n^{l+j} \rightarrow \infty$. We normalize by taking $\sum_{j \in A} (z_n^j / z_n^{l+j}) = 1$. Call $p_n^j = z_n^j / z_n^{l+j}$, $j \in A$. Then we can assume that $p_n^j \rightarrow p^j$. By putting $p^j = 0$ if $j \notin A$, we have a vector $p \in R^l$. It is a simple exercise to verify that for (almost) all i , $px(i) = 0$. Suppose now by way of contradiction that for some i (strictly speaking for a set of i 's of positive measure) $pv < 0$, $v^j = 0$ for $j \notin A$, $\omega_i + v \geq 0$ and $\omega_i + v >_i \omega_i + x(i)$. Let the type of i be h . Then we can find a sequence i_n such that the type of i_n is h and $\omega_h + v >_h \omega_h + x_n(i_n)$. Let g_n define the frontier of the attainable set of i_n in the economy \mathcal{E}_n . Then (see Section 2.2),

$$g_n(v) = \sum_j \frac{z_n^j - m_n^j(i_n)}{z_n^{l+j} - y_n^j(i_n) - v^j} v^j$$

But $z_n^{l+j} \rightarrow \infty$ and $y_n^j(i_n)$, $m_n^j(i_n)$ are uniformly bounded (by lr where r is an upper bound for the endowments of any commodity). So, for n large enough, $g_n(v) \leq 0$, but this contradicts the preference maximization requirement on $x_n(i_n)$.

4.4 Proof of Theorem 3

The proof is entirely similar, only even simpler, than the proof of Theorem 1. Let $q = P(\bar{y})$. Those are the obvious Walrasian equilibrium prices. Suppose that for some $i \in I$ (strictly speaking, for a set of i 's of positive measure) we have $qv > qy(i)$ for some $v \in Y(i)$. Put $\epsilon = qv - qy(i)$. Then, for some N and $i_n \in I_n$, $n > N$, we have

$$qv > qy_n(i_n) + \epsilon/2, \quad v \in Y_n(i_n), \quad y_n(i_n) \rightarrow y(i)$$

Let \bar{y}'_n be equal to y_n except that $y_n(i_n)$ is replaced by v . Then $\bar{y}_n \rightarrow \bar{y}$ and $\bar{y}'_n \in \hat{Y} \subset J$. Therefore, by continuity of P , $P(\bar{y}'_n) \rightarrow q$. So, for n large enough, $P(\bar{y}'_n)v > P(\bar{y}'_n)y_n(i_n)$, which contradicts the fact that y_n is a CN production.

4.5 Proof of Theorem 4

We shall only provide a concise argument. The reason is that we follow the same general proof strategy as for Theorem 2 and also that we have

nothing to add to Roberts's (1980) proof. We refer to Mas-Colell (1981) for a careful proof of a generalization of Theorem 4 to the nonconvex case.

Let \mathcal{E}_n , \mathcal{E} , and (y, q) be as in the statement of the theorem. Let $A \subset J$, $B \subset R^l$, be as in the statement of Condition U . Take $B' \subset B$ bounded and such that $S(\bar{B}') \subset A$.

Consider type h with Walrasian production y_h . The hypothesis that S is a C^1 function on B implies, with the convexity and boundedness of each Y_h , that the supply correspondence of h , S_h , is a C^1 function on B . This is not obvious, but it can be proved. If we let L be a sufficiently small neighborhood of zero in the space of $l \times l$ real matrices and if B is taken sufficiently small, then the generalized demand correspondence $\xi_h: B \times L \rightarrow R^l$ defined by letting $\xi_h(v, L)$ be the solutions to the problem $\text{Max}_{y_h \in Y_h} (vy_h + y_h Ly_h)$, is also a C^1 function (see Roberts (1980) for a proof). Intuitively, the hypothesis that S_h is C^1 (hence, Lipschitzian) implies that the relevant region of the boundary of Y_h has nonzero curvature, which in turn yields that the generalized supply is a function (which is the essential fact). We may note that this curvature aspect is specific to the proof of this theorem and has no analog in the proof of Theorem 2 (for which the relevant convexity conditions are always satisfied).

In the arguments to follow we always take n to be large enough for them to be justified. Suppose that in the economy \mathcal{E}_n , $y_n: I_n \rightarrow R^l$ is an attainable allocation such that for all $i \in I_n$, if i is of type h , then $y_n(i) = \xi_h(p(\bar{y}_n), (1/2\#I_n)Dp(\bar{y}_n))$. We claim that y_n must be a CN production. To verify this it suffices to make two observations: (i) For each i , the direct computation yields that the gradients computed at $y(i)$ of the profit function used to define the generalized demand (with $v = p(\bar{y}_n)$, $L = (1/2\#I_n)Dp(\bar{y}_n)$) and of the Cournotian profit function are identical. In other words, the first-order conditions of the Cournot maximization problem are satisfied; (ii) Because of the same curvature arguments of the previous paragraph, if n is large, then the second-order sufficient conditions will be automatically satisfied. Indeed, the isoprofit manifolds of the Cournot problem are almost linear and the production sets are bounded, convex, and with boundaries having some curvature.

Let $A' \subset A$ be a neighborhood of \bar{y} with $p(A') \subset B'$. For each sufficiently large n , define

$$H_n: A' \rightarrow R^l \quad \text{by} \quad H_n(z) = \sum_h \theta_n^h \xi_h \left(p(z), \frac{1}{2\#I_n} Dp(z) \right) - z$$

Then, if $H_n(z) = 0$, we can determine a CN production y_n by putting $y_n(i) = \xi_h(p(z), (1/2\#I_n)Dp(z))$ if agent i is of type h . We also define

$H: A' \rightarrow R^l$ by $H(z) = S(p(z)) - z$ and note that $H_n \rightarrow H$, C^1 uniformly. As in the proof of Theorem 2 one verifies that $\text{rank } DG(q) = l$ if and only if $\text{rank } DH(\bar{y}) = l$. Therefore, by the regularity condition and the implicit function theorem (see proof of Theorem 2) there is $z_n \rightarrow \bar{y}$, $H(z_n) = 0$. From this we derive CN productions $y_n \rightarrow y$ and conclude the proof. Observe that the dimensionality of the domain of H_n is independent of the number of types.

REFERENCES

- Arrow, K. and Hahn, F. (1971). *General competitive analysis*. San Francisco: Holden-Day.
- Aumann, R. (1964). Markets with a continuum of traders. *Econometrica* 32: 39-50.
- Cournot, A. (1838). *Recherches sur les principes mathématiques de la théorie des richesses*. Paris: Rivière. Translated by Nathaniel T. Bacon (1897). *Researches into the mathematical principles of theory of wealth*. New York: Macmillan.
- Debreu, G. (1959). *Theory of value*. New York: Wiley.
- Debreu, G. (1970). Economies with a finite set of equilibria. *Econometrica* 38: 387-392.
- Debreu, G. (1972). Smooth preferences. *Econometrica* 40:603-615.
- Dierker, E. (1977). Regular economies: a survey. In *Frontiers of quantitative economics III*, M. Intriligator, ed. Amsterdam: North-Holland.
- Dubey, P. (1981). Price-quantity strategic market games, *Econometrica* 50: 111-126.
- Dubey, P., Mas-Colell, A. and Shubik, M. (1980). Efficiency properties of strategic market games: an axiomatic approach, *J. Econ. Theory*, Symposium issue, April 1980, pp. 339-363.
- Dubey, P. and Shapley, L. (1977). Non-cooperative exchange with a continuum of traders, RAND Report P-5964, Santa Monica, California.
- Dubey, P. and Shubik, M. (1977). A closed economic system with production and exchange modeled as a game of strategy, *J. Math. Economics* 4: 253-287.
- Gabszewicz, J. and Vial, J. P. (1972). Oligopoly "à la Cournot" in a general equilibrium analysis. *J. Econ. Theory* 4: 381-400.
- Hart, O. (1979a). Monopolistic competition in a large economy with differentiated commodities. *Rev. Econ. Stud.* 46: 1-30.
- Hart, O. (1979b). On shareholders unanimity in large stock market economies. *Econometrica* 47: 1057-1085.
- Hart, O. (1980). Perfect competition and optimal product differentiation. *J. Econ. Theory*, Symposium volume, April 1980, pp. 279-313.
- Hildenbrand, W. (1974). *Core and equilibria of a large economy*. Princeton: Princeton University Press.
- Jaynes, J., Okuno, M. and Schmeidler, D. (1978). Efficiency in an atomless economy with fiat money. *Internat. Econ. Rev.* 19: 149-157.
- Journal of Economic Theory* (1980), vol. 22, no. 2, April 1980, Symposium issue on *Noncooperative approaches to the theory of perfect competition*.

- Makowski, L. (1980a). A characterization of perfectly competitive economies with production. *J. Econ. Theory*, Symposium issue, April 1980, pp. 208-222.
- Makowski, L. (1980b). Perfect competition, the profit criterion, and the organization of economic activity. *J. Econ. Theory*, Symposium issue, April 1980, pp. 222-243.
- Mas-Colell, A. (1981). Walrasian equilibria as limits of mixed strategy non-cooperative equilibria, CRM IP-293, University of California, Berkeley.
- Mas-Colell, A. (1982). Perfect competition and the core. *Review of Econ. Studies* 44: 15-30.
- Novshek, W. and Sonnenschein, H. (1978). Cournot and Walras equilibrium. *J. Econ. Theory* 19: 223-266.
- Novshek, W. and Sonnenschein, H. (1979). Private communication.
- Novshek, W. and Sonnenschein, H. (1980). Small efficient scale as a foundation for Walrasian equilibrium. *J. Econ. Theory*, Symposium issue, April 1980, pp. 243-256.
- Ostroy, J. (1980). The no-surplus condition as a characterization of perfectly competitive equilibrium. *J. Econ. Theory*, Symposium issue, April 1980, pp. 183-208.
- Pazner, E. and Schmeidler, D. (1976). Non-Walrasian equilibria and Arrow-Debreu economies. Mimeographed, University of Illinois, Urbana.
- Pearce, I. (1952-53). Total demand curves and general equilibrium, *Rev. Econ. Stud.* 20: 216-227.
- Postlewaite, A. and Schmeidler, D. (1978). Approximate efficiency of non-Walrasian Nash equilibria. *Econometrica* 46: 127-137.
- Roberts, J. and Postlewaite, A. (1974). The incentives for price-taking behavior in large exchange economies. *Econometrica* 44: 115-127.
- Roberts, J. and Sonnenschein, H. (1977). On the foundations of the theory of monopolistic competition, *Econometrica* 45: 101-113.
- Roberts, K. (1980). The limit points of monopolistic competition. *J. Econ. Theory*, Symposium issue, pp. 256-279.
- Schmeidler, D. (1980). Walrasian analysis via strategic outcome functions, *Econometrica* 48: 1585-1595.
- Schwartz, L. (1967). *Cours d'Analyse I*, Paris: Hermann.
- Shafer, W. and Sonnenschein, H. (1982). Market demand and excess demand functions. Chapter 14, in *Handbook of Mathematical Economics*, Vol II, K. Arrow and M. Intriligator, eds. Amsterdam: North-Holland.
- Shapley, L. (1976). Non-cooperative general exchange. In *Theory and Measurement of Economic Externalities*, S. A. Y. Lin, ed. New York: Academic Press.
- Shapley, L. and Shubik, M. (1977). Trade using one commodity as a means of payment. *J. Pol. Econ.* 85: 937-968.
- Shubik, M. (1973). Commodity money, oligopoly, credit and bankruptcy in a general equilibrium model. *Western Econ. J.* 11: 24-28.
- Simon, L. (1981). Bertrand and Walras equilibrium. *Econometric Research Memorandum*, No. 282, Princeton, N.J.